



Level



Pressure



Flow



Temperature

Liquid
Analysis

Registration

Systems
Components

Services



Solutions

Technical Information

Prosonic S

FDU91/91F/92/93/95/96

Ultrasonic sensors for non-contact continuous level and flow measurement;
for connection to the transmitter FMU90



FDU91



FDU92



FDU91F



FDU93



FDU95



FDU96

Application

- Continuous, non-contact level measurement of fluids, pastes, sludges and powdery to coarse bulk materials
- Flow measurement in open channels and measuring weirs
- Maximum measuring range
 - FDU91/FDU91F:
 - 10 m in fluids
 - 5 m in bulk materials
 - FDU92:
 - 20 m in fluids
 - 10 m in bulk materials
 - FDU93:
 - 25 m in fluids
 - 15 m in bulk materials
 - FDU95:
 - 45 m in bulk materials
 - FDU96:
 - 70 m in bulk materials
- Suited for explosion hazardous areas

Your benefits

- Non-contact measurement method; minimizes service requirements
- Integrated temperature sensor for time-of-flight correction. Accurate measurements are possible, even if temperature changes are present
- Hermetically welded PVDF sensors FDU91/92 for fluid measurement; for highest chemical resistance
- Integrated automatical sensor detection for transmitters FMU90; simple commissioning
- Can be installed up to 300 m from the transmitter
- Suited for rough ambient conditions thanks to separate installation from the transmitter
- Insensitive to dirt and build-up because of the self-cleaning effect
- Integrated heating against a build-up of ice at the sensor (optional); ensures reliable measurement
- Weather resistant and flood-proof (IP68)
- Dust-Ex and Gas-Ex certificates available (ATEX, FM, CSA)

Function and system design

Measuring principle

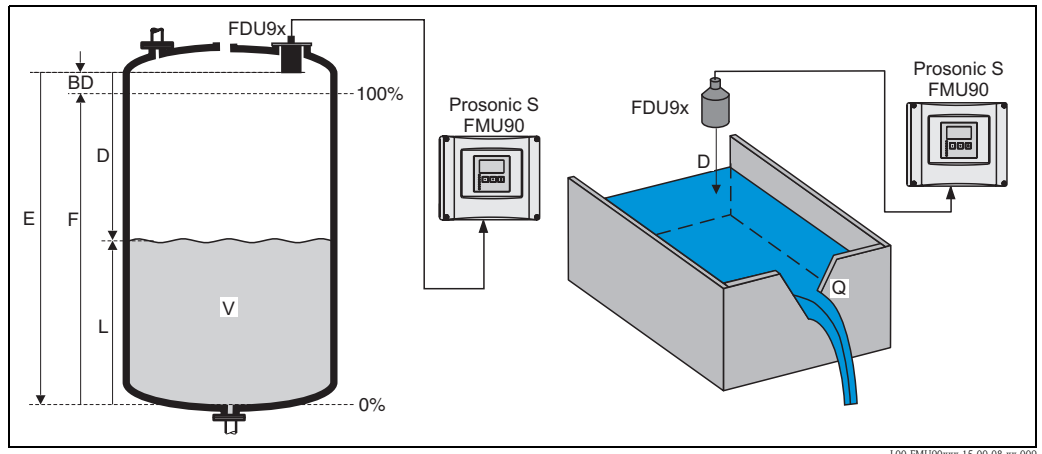

BD: blocking distance; **D:** distance from sensor membrane to fluid surface; **E:** empty distance **F:** span (full distance); **L:** level; **V:** volume (or mass); **Q:** flow

The sensor transmits ultrasonic pulses in the direction of the product surface. There, they are reflected back and received by the sensor. The transmitter Prosonic S measures the time t between pulse transmission and reception. From t (and the velocity of sound c) it calculates the distance D from the sensor membrane to the product surface:

$$D = c \cdot t / 2$$

From D results the desired measuring value:

- level L
- volume V
- flow Q across measuring weirs or open channels

Time-of-flight correction

In order to compensate for temperature dependent time-of-flight changes, a temperature sensor is integrated in the ultrasonic sensors.

Blocking distance

The level L may not extend into the blocking distance BD . Level echoes within the blocking distance can not be evaluated due to the transient characteristics of the sensor and thus a reliable measurement is not possible. The blocking distance BD is dependent on the type of sensor:

| Type of sensor | Blocking distance (BD) |
|--|------------------------|
| FDU91/FDU91F | 0,3 m |
| FDU92 | 0,4 m |
| FDU93 | 0,6 m |
| FDU95 - *1*** (low temperature version) | 0,7 m |
| FDU95 - *2*** (high temperature version) | 0,9 m |
| FDU96 | 1,6 m |

Transmitter

The sensors can be connected to the transmitter FMU90. The transmitter recognizes the type of sensor automatically.

Ordering information

Product structure FDU91

| | | | |
|------------|---|---|---------------------|
| 010 | Approval | | |
| | R | Non-hazardous area | |
| | J | ATEX II 2G EEx ma II T6 | |
| | G | ATEX II 3G EEx nA II T6 (in preparation) | |
| | E | ATEX II 1/2 D, ATEX II 2G Ex ma II T6 | |
| | H | ATEX II 3D (in preparation) | |
| | U | CSA General Purpose (in preparation) | |
| | S | CSA Cl.I,II,III Div.1+2 Gr.A-G (in preparation) | |
| | Q | FM Cl.I,II,III Div. 1+2 Gr.A-G (in preparation) | |
| | V | TIIS Ex is IIC T6 (in preparation) | |
| 020 | Process connection (threaded boss) | | |
| | G | Thread ISO228 G1, PVDF | |
| | N | Thread ANSI NPT1, PVDF | |
| 030 | Cable length | | |
| | 1 | 5 m | |
| | 2 | 10 m | |
| | 3 | 15 m | |
| | 4 | 20 m | |
| | 5 | 25 m | |
| | 6 | 30 m | |
| | 8 | ... m (variable length, up to 300 m) | |
| | A | ... ft (variable length, up to 985 ft) | |
| 035 | Heater | | |
| | A | w/o heater | |
| | B | Connection to 24 VDC (in preparation) | |
| 040 | Additional option | | |
| | A | Basic version | |
| FDU91 - | | | product designation |

Product structure FDU91F

| | | | |
|------------|---------------------------|--|---------------------|
| 010 | Approval | | |
| | R | Non-hazardous area | |
| | J | ATEX II 2G EEx ma II T5 (in preparation) | |
| | G | ATEX II 3G EEx nA II T6 (in preparation) | |
| | E | ATEX II 1/2 D, ATEX II 2G Ex ma II T6 (in preparation) | |
| | H | ATEX II 3D (in preparation) | |
| | U | CSA General Purpose (in preparation) | |
| | S | CSA Cl.I,II,III Div.1+2 Gr.A-G (in preparation) | |
| | Q | FM Cl.I,II,III Div. 1+2 Gr.A-G (in preparation) | |
| | V | TIIS Ex is IIC T6 (in preparation) | |
| 020 | Process connection | | |
| | G | Thread ISO228 G1, 316L | |
| | N | Thread ANSI NPT1, 316L | |
| | F | Flush mounting; prepared for slip-on flange FAU80, 3A | |
| | T | Tri-Clamp ISO2852 DN80, 316L, 3A | |
| 030 | Cable length | | |
| | 1 | 5 m | |
| | 2 | 10 m | |
| | 3 | 15 m | |
| | 4 | 20 m | |
| | 5 | 25 m | |
| | 6 | 30 m | |
| | 8 | ... m (variable length, up to 300 m) | |
| | A | ... ft (variable length, up to 985 ft) | |
| 040 | Additional option | | |
| | A | Basic version | |
| FDU91F - | | | product designation |

Product structure FDU92

| | | | |
|------------|---|---|---|
| 010 | Approval | R | Non-hazardous area |
| | | J | ATEX II 2G EEx m II T6 |
| | | G | ATEX II 3G EEx nA II T6 (in preparation) |
| | | E | ATEX II 1/2 D, ATEX II 2G Ex ma II T6 |
| | | H | ATEX II 3D (in preparation) |
| | | U | CSA General Purpose (in preparation) |
| | | S | CSA Cl.I,II,III Div.1+2 Gr.A-G (in preparation) |
| | | Q | FM Cl.I,II,III Div. 1+2 Gr.A-G (in preparation) |
| | | V | TIIS Ex is IIC T6 (in preparation) |
| 020 | Process connection (threaded boss) | G | Thread ISO228 G1, PVDF |
| | | N | Thread ANSI NPT1, PVDF |
| 030 | Cable length | 1 | 5 m |
| | | 2 | 10 m |
| | | 3 | 15 m |
| | | 4 | 20 m |
| | | 5 | 25 m |
| | | 6 | 30 m |
| | | 8 | ... m (variable length, up to 300 m) |
| | | A | ... ft (variable length, up to 985 ft) |
| 040 | Additional option | A | Basic version |
| FDU92 - | | | product designation |

Product structure FDU93

| | | | |
|------------|---|---|---|
| 010 | Approval | R | Non-hazardous area |
| | | J | ATEX II 2G EEx m II T6, ATEX II 1/2D |
| | | G | ATEX II 3G EEx nA II T6 (in preparation) |
| | | E | ATEX II 1/2 D |
| | | H | ATEX II 3D (in preparation) |
| | | U | CSA General Purpose (in preparation) |
| | | T | CSA Cl.I,II,III Div.1 Gr.E-G (in preparation) |
| | | P | FM Cl.I,II,III Div. 1+2 Gr.A-G (in preparation) |
| | | W | TIIS dust-Ex DP12 (in preparation) |
| 020 | Process connection (threaded boss) | G | Thread ISO228 G1, UP |
| | | N | Thread ANSI NPT1, UP |
| 030 | Cable length | 1 | 5 m |
| | | 2 | 10 m |
| | | 3 | 15 m |
| | | 4 | 20 m |
| | | 5 | 25 m |
| | | 6 | 30 m |
| | | 8 | ... m (variable length, up to 300 m) |
| | | A | ... ft (variable length, up to 985 ft) |
| 040 | Additional option | A | Basic version |
| FDU93 - | | | product designation |

Product structure FDU95

| | | | |
|------------|---|---|--|
| 010 | Approval | R | Non-hazardous area |
| | | J | ATEX II 2G Ex ma II T6, ATEX II 1/D |
| | | E | ATEX II 1/2 D |
| | | H | ATEX II 3D (in preparation) |
| | | P | FM Cl.II Div.1 Gr.E-G (in preparation) |
| | | U | CSA General Purpose (in preparation) |
| | | T | CSA Cl.II Div.1 Gr.E-G (in preparation) |
| | | W | TIIS dust-Ex DP12 (in preparation) |
| 015 | Temperature; blocking distance; material | 1 | -40 ... +80 °C; 70 cm; membrane: 316L; surface: PE |
| | | 2 | -40 ... 150 °C; 90 cm; membrane: 316L |
| 020 | Process connection (threaded boss) | G | Thread ISO228 G1, UP |
| | | N | Thread ANSI NPT1, UP |
| 030 | Cable length | 1 | 5 m |
| | | 2 | 10 m |
| | | 3 | 15 m |
| | | 4 | 20 m |
| | | 5 | 25 m |
| | | 6 | 30 m |
| | | 8 | ... m (variable length, up to 300 m) |
| | | A | ... ft (variable length, up to 985 ft) |
| 040 | Additional option | A | Basic version |
| FDU95 - | | | product designation |

Product structure FDU96

| | | | |
|------------|---|---|--|
| 010 | Approval | R | Non-hazardous area |
| | | J | ATEX II 2G EEx ma II T6, ATEX II 1/2D |
| | | E | ATEX II 1/2 D, -40 ... +140 °C |
| | | F | ATEX II 1/2 D, -40 ... +80 °C |
| | | H | ATEX II 3D (in preparation) |
| | | U | CSA General Purpose (in preparation) |
| | | L | CSA Cl.I,II,III Div.1 Gr.E-G; LT; Ambient temperature: -40 ... +80 °C (176 °F) (in preparation) |
| | | T | CSA Cl.I,II,III Div.1 Gr.E-G; HT; Ambient temperature: -40 ... +140 °C (284 °F) (in preparation) |
| | | P | FM Cl.I,II,III Div. 1+2 Gr.A-G; HT; Ambient temperature: -40 ... +140 °C (284 °F) (in preparation) |
| | | K | FM Cl.I,II,III Div. 1+2 Gr.A-G; LT; Ambient temperature: -40 ... +80 °C (176 °F) (in preparation) |
| | | W | TIIS dust-Ex DP12 (in preparation) |
| 020 | Process connection (threaded boss) | G | Thread ISO228 G1, UP |
| | | S | Thread ISO228 G1, 304 |
| | | N | Thread ANSI NPT1, UP |
| | | V | Thread ANSI NPT1, 304 |
| 030 | Cable length | 1 | 5 m |
| | | 2 | 10 m |
| | | 3 | 15 m |
| | | 4 | 20 m |
| | | 5 | 25 m |
| | | 6 | 30 m |
| | | 8 | ... m (variable length, up to 300 m) |
| | | A | ... ft (variable length, up to 985 ft) |
| 040 | Additional options | A | Basic version |
| FDU96 - | | | product designation |

广州晋合水处理设备有限公司



地 址：广东省广州市海珠区工业大道333号华新园区7幢218
电 话：020-88191905
传 真：020-61139917
邮 编：510300
邮 箱：jinhewater@jinhewater.com
网 址：<http://www.jinhewater.com>

Endress+Hauser 
People for Process Automation