



Level



Pressure



Flow



Temperature



Liquid  
Analysis



Registration



Systems  
Components



Services



Solutions

## Technical Information

# Proline Promass 84F, 84M

## Coriolis Mass Flow Measuring System

The universal and multivariable flowmeter for liquids and gases for custody transfer



### Applications

The Coriolis measuring principle operates independently of the physical fluid properties, such as viscosity and density.

- Extremely accurate, verified measurement of liquids (other than water) and for gases under high pressure (> 100 bar)
- Fluid temperatures up to +350 °C
- Process pressures up to 350 bar
- Mass flow measurement up to 2200 t/h

Approvals for custody transfer:

- PTB, NMI, METAS, BEV, NTEP, MC

Approvals for hazardous area:

- ATEX, FM, CSA, TIIS

Approvals in the food industry/hygiene sector:

- 3A, FDA

Connection to process control system:

- HART

Relevant safety aspects:

- Secondary containment (up to 100 bar), Pressure Equipment Directive

### Your benefits

The Promass measuring devices make it possible to simultaneously record several process variables (mass/density/temperature) for various process conditions during measuring operation.

The **Proline transmitter concept** comprises:

- Modular device and operating concept resulting in a higher degree of efficiency
- Diagnostic ability and data back-up for increased process quality

The **Promass sensors**, tried and tested in over 100000 applications, offer:

- Multivariable flow measurement in compact design
- Insensitivity to vibrations thanks to balanced two-tube measuring system
- Immune from external piping forces due to robust design
- Easy installation without taking inlet and outlet runs into consideration



## Function and system design

### Measuring principle

The measuring principle is based on the controlled generation of Coriolis forces. These forces are always present when both translational and rotational movements are superimposed.

$$F_C = 2 \cdot \Delta m (v \cdot \omega)$$

$F_C$  = Coriolis force

$\Delta m$  = moving mass

$\omega$  = rotational velocity

$v$  = radial velocity in rotating or oscillating system

The amplitude of the Coriolis force depends on the moving mass  $\Delta m$ , its velocity  $v$  in the system, and thus on the mass flow. Instead of a constant angular velocity  $\omega$ , the Promass sensor uses oscillation.

In the Promass F and M sensors, two parallel measuring tubes containing flowing fluid oscillate in antiphase, acting like a tuning fork. The Coriolis forces produced at the measuring tubes cause a phase shift in the tube oscillations (see illustration):

- At zero flow, in other words when the fluid is at a standstill, the two tubes oscillate in phase (1).
- Mass flow causes deceleration of the oscillation at the inlet of the tubes (2) and acceleration at the outlet (3).

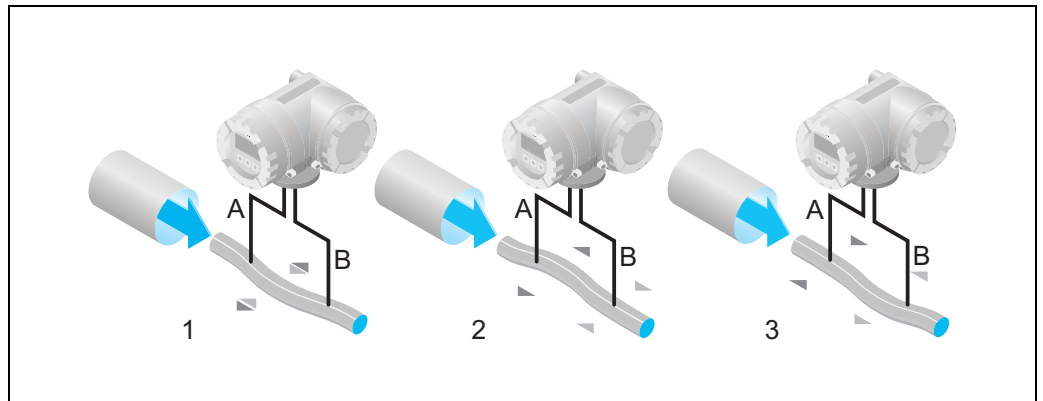

a0003383

The phase difference (A-B) increases with increasing mass flow. Electrodynamic sensors register the tube oscillations at the inlet and outlet.

System balance is ensured by the antiphase oscillation of the two measuring tubes. The measuring principle operates independently of temperature, pressure, viscosity, conductivity and flow profile.

### Density measurement

The measuring tubes are continuously excited at their resonance frequency. A change in the mass and thus the density of the oscillating system (comprising measuring tubes and fluid) results in a corresponding, automatic adjustment in the oscillation frequency. Resonance frequency is thus a function of fluid density. The micro-processor utilises this relationship to obtain a density signal.

### Temperature measurement

The temperature of the measuring tubes is determined in order to calculate the compensation factor due to temperature effects. This signal corresponds to the process temperature and is also available as an output. The temperature measurement cannot be used to generate data for invoicing in applications subject to legal metrology controls.

**Measuring system**

The measuring system consists of a transmitter and a sensor. Two versions are available:

- Compact version: transmitter and sensor form a single mechanical unit.
- Remote version: transmitter and sensor are installed separately.

**Transmitter**

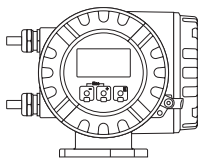
<p><b>Promass 84</b></p>  <p style="text-align: right; font-size: small;">a0003672</p>	<ul style="list-style-type: none"> <li>■ Four-line liquid-crystal display</li> <li>■ Operation with "Touch control"</li> <li>■ Application-specific Quick Setup</li> <li>■ Mass flow, volume flow, density and temperature measurement as well as calculated variables (e.g. corrected volume flow)</li> </ul>
---	--

**Sensor**

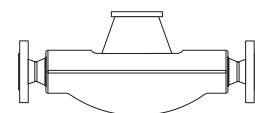
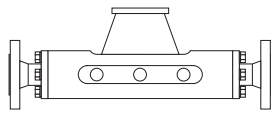
<p><b>F</b></p>  <p style="text-align: right; font-size: small;">a0003673</p>	<ul style="list-style-type: none"> <li>■ Universal sensor for fluid temperatures up to 350 °C</li> <li>■ Nominal diameters DN 8 to 250</li> <li>■ Measuring tubes made of stainless steel or Alloy C-22</li> </ul>
<p><b>M</b></p>  <p style="text-align: right; font-size: small;">a0003676</p>	<ul style="list-style-type: none"> <li>■ Robust sensor for extreme process pressures, high secondary containment requirements and fluid temperatures up to 150 °C</li> <li>■ Nominal diameters DN 8 to 80</li> <li>■ Tube material: titanium</li> </ul>

**Further sensor in separate documentation**

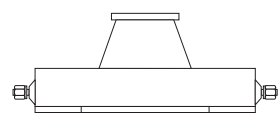
<p><b>A</b></p>  <p style="text-align: right; font-size: small;">a0003679</p>	<ul style="list-style-type: none"> <li>■ Single-tube system for highly accurate measurement of very small flows</li> <li>■ Nominal diameters DN 2 to 4</li> <li>■ Measuring tube made of stainless steel or Alloy C-22</li> </ul>	<p>Documentation No. TI068D/06/en</p>
--	---	---

## Input

### Measured variable

- Mass flow (proportional to the phase difference between two sensors mounted on the measuring tube to register a phase shift in the oscillation)
- Fluid density (proportional to resonance frequency of the measuring tube)
- Fluid temperature (measured with temperature sensors)

### Measuring range in non-custody transfer mode

#### Measuring ranges for liquids

DN [mm]	Promass	Range for full scale values (liquids) $\dot{m}_{\min(F)}$ to $\dot{m}_{\max(F)}$ [kg/h]
8	F, M	0 to 2000
15	F, M	0 to 6500
25	F, M	0 to 18000
40	F, M	0 to 45000
50	F, M	0 to 70000
80	F, M	0 to 180000
100	F	0 to 350000
150	F	0 to 800000
250	F	0 to 22 00000

#### Measuring ranges for gases

The full scale values depend on the density of the gas. Use the formula below to calculate the full scale values:

$$\dot{m}_{\max(G)} = \dot{m}_{\max(F)} \cdot \rho_{(G)} / x \text{ [kg/m}^3\text{]}$$

$$\dot{m}_{\max(G)} = \text{Max. full scale value for gas [kg/h]}$$

$$\dot{m}_{\max(F)} = \text{Max. full scale value for liquid [kg/h]}$$

$$\rho_{(G)} = \text{Gas density in [kg/m}^3\text{] for process conditions}$$

$$x = 160 \text{ (Promass F DN 8 to 100, M); } x = 250 \text{ (Promass F DN 150 to 250)}$$

Here,  $\dot{m}_{\max(G)}$  can never be greater than  $\dot{m}_{\max(F)}$

*Calculation example for gas:*

- Sensor type: Promass F, DN 50
- Gas: air with a density of 60.3 kg/m<sup>3</sup> (at 20 °C and 50 bar)
- Measuring range: 70000 kg/h
- $x = 160$  (for Promass F DN 50)

Max. possible full scale value:

$$\dot{m}_{\max(G)} = \dot{m}_{\max(F)} \cdot \rho_{(G)} / x \text{ [kg/m}^3\text{]} = 70000 \text{ kg/h} \cdot 60.3 \text{ kg/m}^3 \div 160 \text{ kg/m}^3 = 26400 \text{ kg/h}$$

*Recommended full scale values*

See information in chapter "Limiting flow" → Page 21 ff.

**Measuring range in custody transfer mode**

The following are example data for German PTB approval (liquids other than water).

**Measuring ranges for liquids in mass flow for Promass F**

DN [mm]	Mass flow (liquids) $Q_{\min}$ to $Q_{\max}$ [kg/min]	Smallest measured quantity [kg]
8	1.5 to 30	0.5
15	5 to 100	2
25	15 to 300	5
40	35 to 700	20
50	50 to 1000	50
80	150 to 3000	100
100	200 to 4500	200
150	350 to 12000	500
250	1500 to 35000	1000

**Measuring ranges for liquids in mass flow for Promass M**

DN [mm]	Mass flow (liquids) $Q_{\min}$ to $Q_{\max}$ [kg/min]	Smallest measured quantity [kg]
8	1.5 to 30	0.5
15	5 to 100	2
25	15 to 300	5
40	35 to 700	20
50	50 to 1000	50
80	150 to 3000	100

**Measuring ranges for liquids in volume flow (also LPG) for Promass F**

DN [mm]	Volume flow (liquids) $Q_{\min}$ to $Q_{\max}$ [l/min]	Smallest measured quantity [l]
8	1.5 to 30	0.5
15	5 to 100	2.0
25	15 to 300	5.0
40	35 to 700	20
50	50 to 1000	50
80	150 to 3000	100
100	200 to 4500	200
150	350 to 12000	500
250	1500 to 35000	1000

**Measuring ranges for liquids in volume flow (also LPG) for Promass M**

DN [mm]	Volume flow (liquids) $Q_{\min}$ to $Q_{\max}$ [l/min]	Smallest measured quantity [l]
80	150 to 3000	100

**Measuring ranges for high pressure fuel gases CNG for Promass M**

DN [mm]	Mass flow (liquids) $Q_{\min}$ to $Q_{\max}$ [kg/min]	Smallest measured quantity [kg]
8	0.1 to 10	0.2
15	0.3 to 40	0.5
25	1.0 to 100	2.0

Max. Pressure = 250 bar resp. 350 bar for high pressure version



Note!

For information about the other approvals → see corresponding certificate.

**Operable flow range**

Over 20 : 1 for verified device

**Input signal****Status input (auxiliary input), HART:**U = 3 to 30 V DC,  $R_i = 5 \text{ k}\Omega$ , galvanically isolated.

Configurable for: totalizer reset, positive zero return, error message reset, zero point adjustment start.

**Status input (auxiliary input), MODBUS RS485:**U = 3 to 30 V DC,  $R_i = 3 \text{ k}\Omega$ , galvanically isolated, switch level: 3 to 30 V DC, independent of polarity.

Configurable for: totalizer reset, positive zero return, error message reset, zero point adjustment start.

**Output****Output signal****Current output:**Active/passive selectable, galvanically isolated, time constant selectable (0.05 to 100 s), full scale value selectable, temperature coefficient: typically 0.005% o.r./°C, resolution: 0.5  $\mu\text{A}$ 

- Active: 0/4 to 20 mA,  $R_L < 700 \Omega$  (for HART:  $R_L \geq 250 \Omega$ )
- Passive: 4 to 20 mA; supply voltage  $V_S$  18 to 30 V DC;  $R_i \geq 150 \Omega$

o.r. = of reading

**Pulse / frequency output, HART:**

For custody transfer measurement, two pulse outputs can be operated.

Passive, galvanically isolated, open collector, 30 V DC, 250 mA

- Frequency output:  
Full scale frequency 2 to 10000 Hz ( $f_{\max} = 12500 \text{ Hz}$ ), on/off ratio 1:1, pulse width max. 2 s.  
In "Phase-shifted pulse outputs" operating mode, the end frequency is limited to a maximum of 5000 Hz.
- Pulse output:  
Pulse value and pulse polarity selectable, pulse width configurable (0.05 to 2000 ms)

**Pulse / frequency output, MODBUS RS485:**

Active/passive selectable, galvanically isolated

- Active: 24 V DC, 25 mA (max. 250 mA during 20 ms),  $R_L > 100 \Omega$
- Passive: Open Collector, 30 V DC, 250 mA
- Frequency output:  
Full scale frequency 2 to 10000 Hz ( $f_{\max} = 12500 \text{ Hz}$ ), on/off ratio 1:1, pulse width max. 2 s.
- Pulse output:  
Pulse value and pulse polarity selectable, pulse width configurable (0.05 to 2000 ms)

**MODBUS RS485**

- MODBUS device type: slave
- Address range: 1 to 247
- Functions codes supported: 03, 04, 06, 08, 16, 23
- Broadcast: supported with the function codes 06, 16, 23
- Physical interface: RS485 in accordance with standard EIA/TIA-485
- Baudrate supported: 1200, 2400, 4800, 9600, 19200, 38400, 57600, 115200 Baud
- Transmission mode: RTU oder ASCII
- Response time:
  - Direct data access = typically 25 to 50 ms
  - Auto-scan buffer (data area) = typically 3 to 5 ms
- Possible output combinations → Page 10

**Relay output:**

Normally closed (NC or break) or normally open (NO or make) contacts available  
 max. 30 V / 0.5 A AC; 60 V / 0.1 A DC,  
 galvanically isolated.

**Signal on alarm**

- **Current output:** Failsafe mode selectable (e.g. in accordance with NAMUR Recommendation NE 43).
- **Pulse/frequency output:** Failsafe mode selectable.
- **Relay output:** De-energised by fault or power supply failure.
- **MODBUS RS485:** If an error occurs, the value NaN (not a number) is output for the process variables.

**Load**

See "Output signal"

**Low flow cut off**

Switch points for low flow cut off are selectable.

DN [mm]	Low flow cutoff / factory settings (v ~ 0.04 m/s) [kg/h]
8	8.00
15	26.0
25	72.0
40	180
50	300
80	720
100	1200
150	2600
250	7200

**Galvanic isolation**

All circuits for inputs, outputs, and power supply are galvanically isolated from each other.

## 广州晋合水处理设备有限公司



® 地 址：广东省广州市海珠区工业大道333号华新园区7幢218  
电 话：020-88191905  
传 真：020-61139917  
邮 编：510300  
邮 箱：jinhewater@jinhewater.com  
网 址：<http://www.jinhewater.com>

**Endress+Hauser**   
People for Process Automation