

Turbidity/Suspended Solids Measurement

Liquisys M CUM 223 / 253

Turbidity and Suspended Solids Transmitter



Liquisys M CUM 223

Liquisys M CUM 253

Due to the modularity of its design, the Liquisys M CUM 223 / 253 transmitter can be adapted to a wide range of customer needs. The basic version, which provides simple measuring and alarm signalling functions, can be equipped with additional software and hardware modules to match specific applications. Retrofitting of expansion modules is also possible.

Areas of application

- Sewage treatment plants, suspended solids measurement
- Effluent treatment
- Water treatment and monitoring
- Drinking water
- Surface water: rivers, lakes, ocean
- Service water
- Indirect discharge
- Water recycling

Benefits at a glance

- Measuring transmitter in field or panel-mounted housing
- Universal application
 - One instrument for turbidity and suspended solids
 - Units: FNU (formazine standard), ppm, g/l, % or % SS
- Simple handling
 - Logically arranged menu structure with plain text in 6 languages facilitates instrument configuration
 - Large, two-line display indicates measured value and temperature at the same time
 - Ultrasimple calibration with user samples and alarm signalling for calibration errors
- Safe operation
 - Overvoltage (lightning) protection according to EN 61000-4-5
 - Direct access for manual contact control
 - User-defined alarm configuration for alarm contact and error current
 - Sensors are factory-calibrated with formazine standard and SiO₂
 - Automatic sensor self-recognition with calibration data transfer

The basic unit can be extended with:

- 2 or 4 contacts for use as:
 - Limit contacts (also for temperature)
 - P(ID) controller
 - Timer for simple rinse processes
 - Complete cleaning with Chemoclean
- Plus package:
 - Any current output configuration via table
 - Automatic initiation of cleaning in case of alarm or limit violation
 - Display in customer units (e.g. density) via table assignment
 - Live check of sensor
- HART® or PROFIBUS-PA
- 2nd current output for temperature



Details

Liquisys M CUM 223 / 253 provides a solution for all drinking water processing, process water and sewage treatment applications.

Features of the **basic version (TU)**:

Measurement of turbidity or suspended solids

This is selected via the menu. During measurement, the value measured can be displayed in the other measuring mode. The **temperature** is displayed at the same time if desired.

2.4 / 22 mA		
E 057	yes	no
E 080	no	yes
----	yes	no

Different alarms are required depending on application and operator. Therefore the Liquisys M CUM 223 / 253 permits independent **configuration of the alarm contact and error current** for each individual error. Unnecessary or undesirable alarms can be suppressed in this manner.

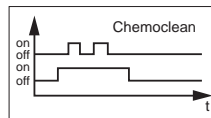
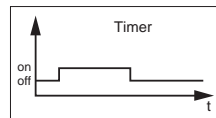

Up to four contacts can be used as limit contacts (also for temperature), to implement a P(ID) controller or for cleaning functions.

Direct **manual operation of the contacts** (bypassing the menu) provides quick access to limit, control or cleaning contacts, permitting speedy correction of deviations.

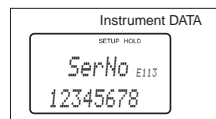

The **serial numbers** of the instrument and modules and the order code can be called up on the display.

The **TS version** version provides **additional functions**:

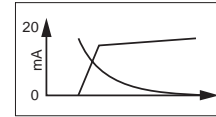

In order to display wide measuring ranges while still achieving a high resolution in specific ranges, the **current output** can be configured as required via a table. This permits **bilinear** or **quasi-logarithmic** curves, etc.

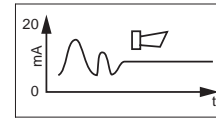

The **live check** issues an alarm when the sensor signal does not change over a defined period of time. This may be caused by blocking, passivation, separation from the process, etc.

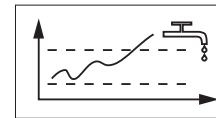

Soiling quickly results in excessive measured values. **Automatic cleaning** prevents alarms and inaccuracy caused by soiling.

In addition to concentration (ppm / % SS), **the display can also show other units** (e.g. density). A table is used for conversion (calibration in %).

Basic version and plus package

	Basic version	With plus package (TS version)
Alarm signalling	MEASUREMENT CALIBRATION (3-pt. / 1-pt. / reflection) Read instrument DATA Linear CURRENT OUTPUT CURRENT OUTPUT simulation 1 programmable ALARM CONTACT (contact and error current)	LIVE CHECK of sensor CURRENT OUTPUT programmable (table)
	<i>Additional features</i>	<i>Additional features</i>
Controlling	2 CHANGEOVER CONTACTS for <ul style="list-style-type: none"> - Measuring parameter limit - Temperature limit - P(ID) controller - Timer for cleaning 	Concentration measurement with assignment to other units Automatic cleaning triggered by alarm or limit violation
	<i>Additional features</i>	<i>Additional features</i>
Cleaning	2 more CHANGEOVER CONTACTS (total of 4) for <ul style="list-style-type: none"> - Measuring parameter limit - Temperature limit - P(ID) controller - Chemoclean cleaning (water and cleaning agent) 	Cleaning triggered externally or automatically by alarm or limit violation

Measuring and control system

A complete measuring system comprises:

- the turbidity/suspended solids transmitter Liquisys M CUM 223 or CUM 253
- a turbidity sensor CUS 31 or suspended solids sensor CUS 41, and

- an immersion, flow or retractable assembly

Options:

- extension cable CYK 8, and
- junction box VBM.

Complete measuring systems with Liquisys M CUM 223 / 253

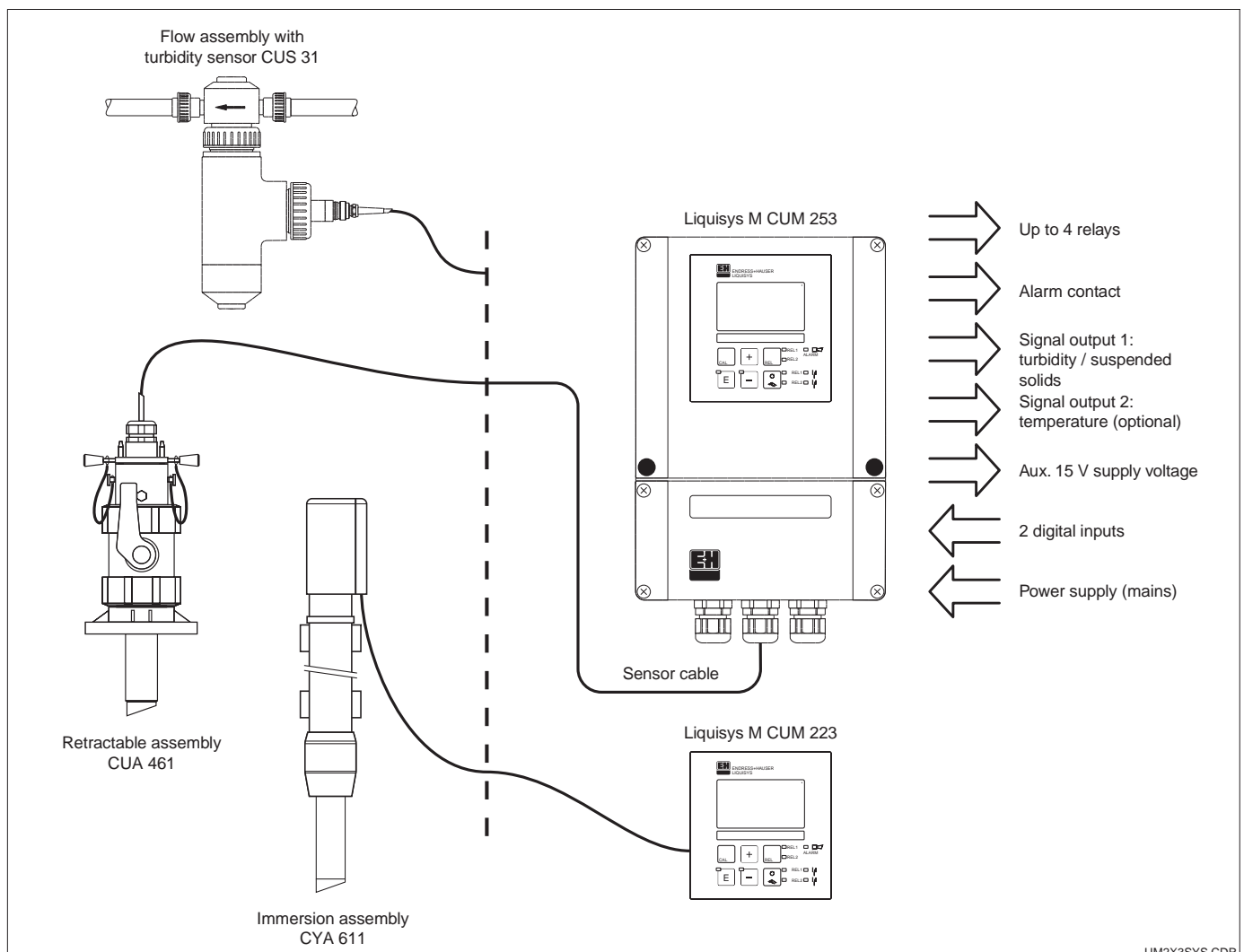

UM2X3SYS.CDR

Operation

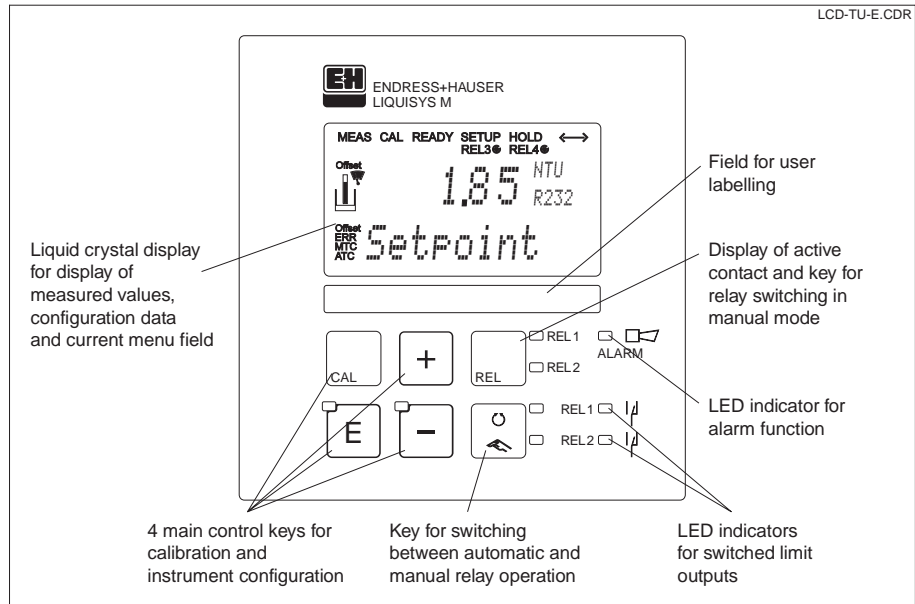

User interface:
Display and keys

Everything at a glance

The display simultaneously shows the current measured value and the temperature – the essential process data. Brief informational texts in the configuration menu provide assistance with parameter configuration.

Intelligent and simple

All instrument control functions are arranged in a logical menu structure. Following access code entry, the individual parameters can be easily selected and modified as needed.

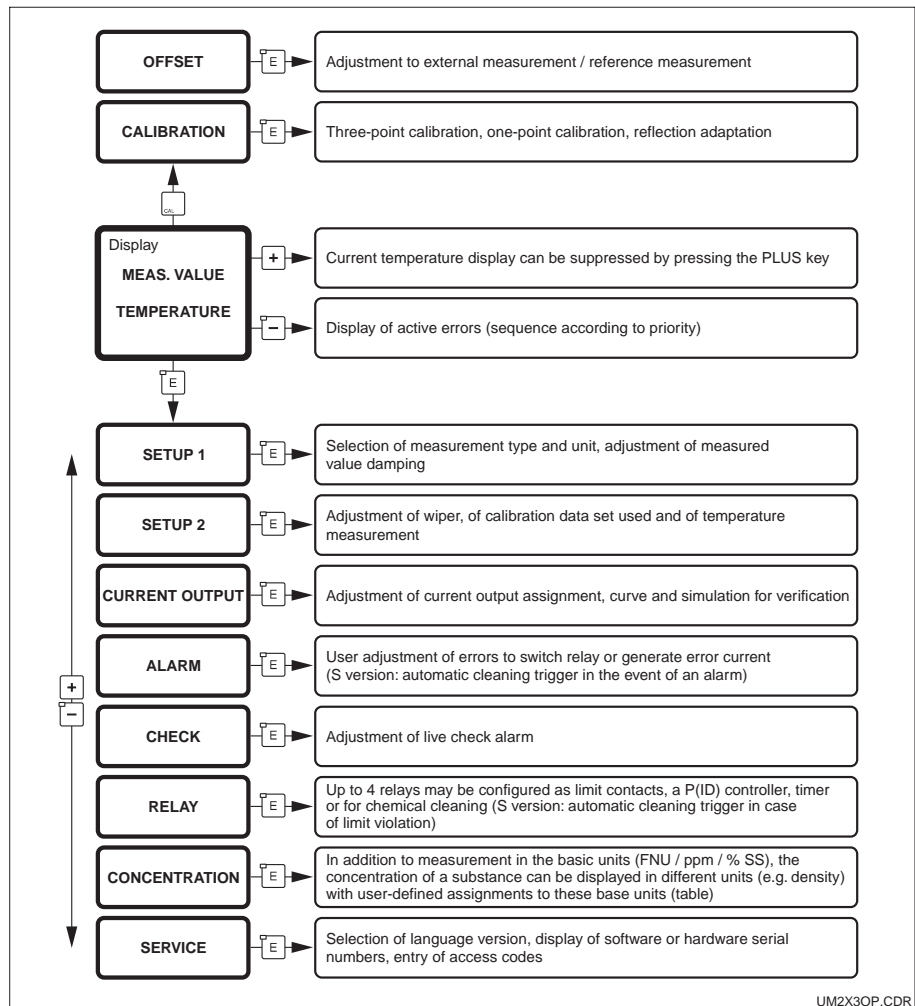

Overview of Liquisys M
CUM 223 / 253 menu.
This overview covers all
the options that can be
installed (see page 2
Details).

Electrical connection

All connections to the panel-mounted instrument CUM 223 are established via the terminal strips on the rear. In the case of the field instrument CUM 253, all wires (including the sensor cable) are connected to terminals in a separate wiring compartment.

All the wiring can remain in place if the instrument needs repair because all possible repairs are limited to assembly replacement. So, Dismantling the instrument and rewiring are no longer necessary.

Left:
Liquisys M CUM 223,
connections on the rear
of the instrument

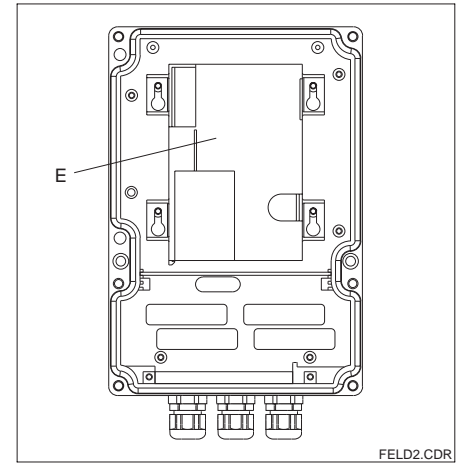

Right:
Liquisys M CUM 253,
rear of instrument with
replaceable electronics
box (E)

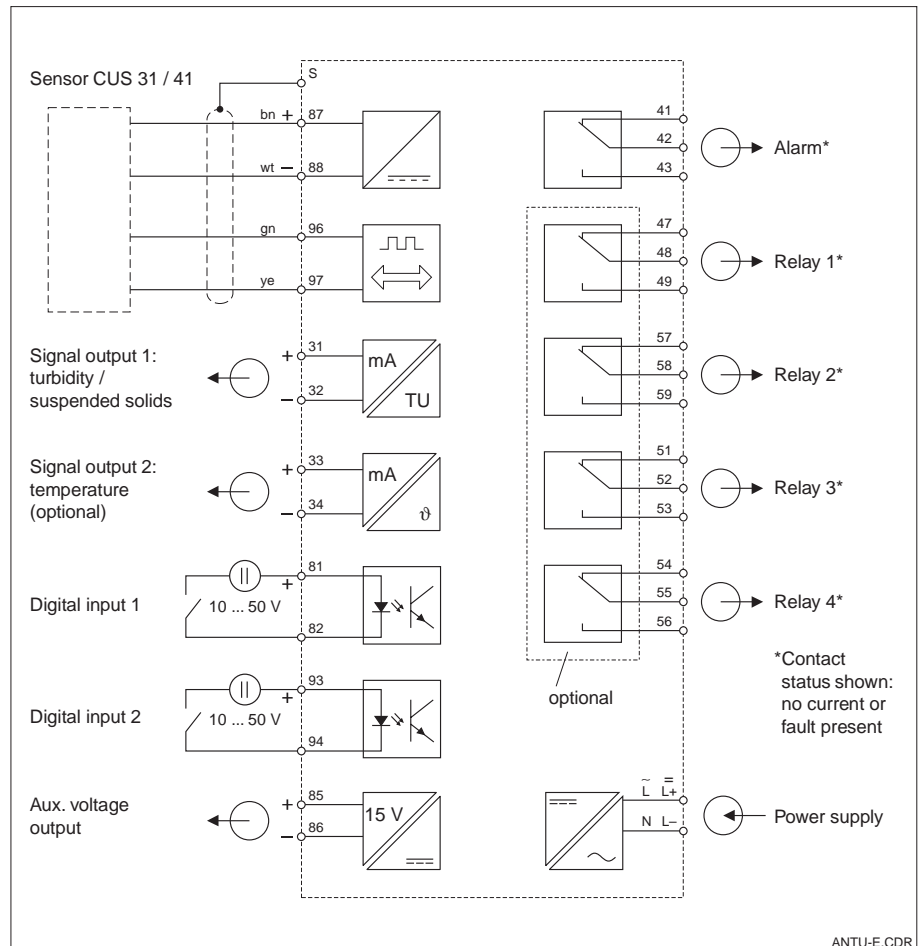

Electrical connection of
Liquisys M CUM 223 /
253

ANTU-E.CDR

Dimensions

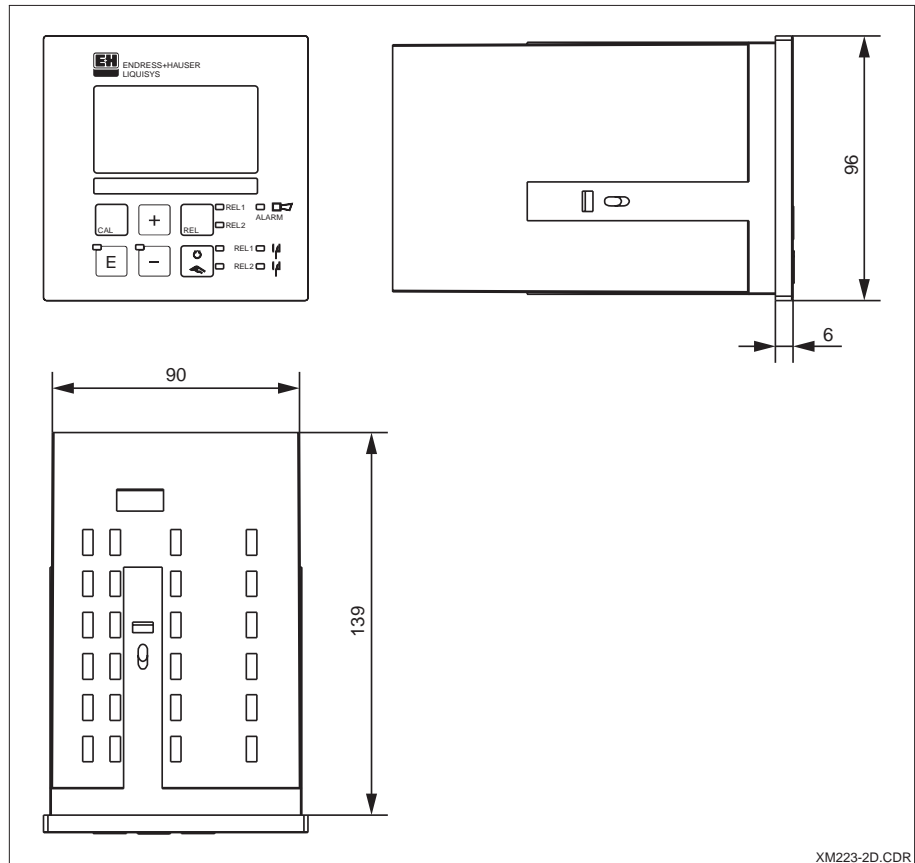

Dimensions of Lquisys M CUM 223

XM223-2D.CDR

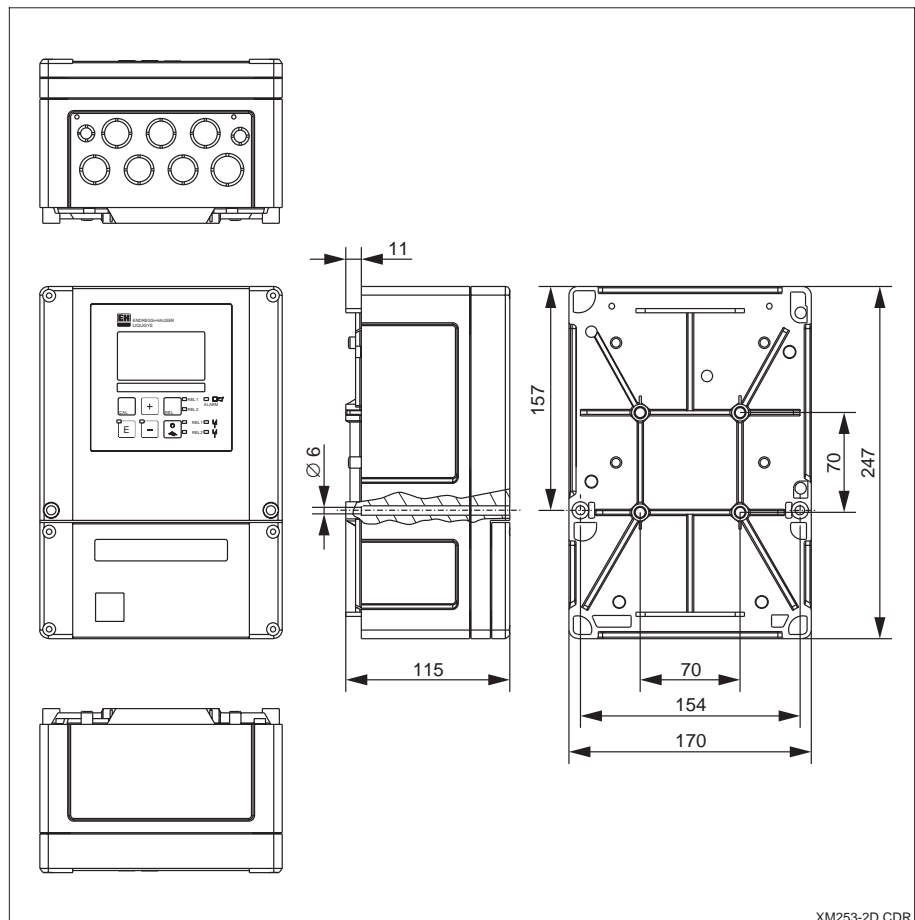

Dimensions of Lquisys M CUM 253

XM253-2D.CDR

Mounting of Liquisys M CUM 223

The panel-mounted version is mounted using the supplied tensioning screws. The required overall mounting depth is approx. 165 mm.

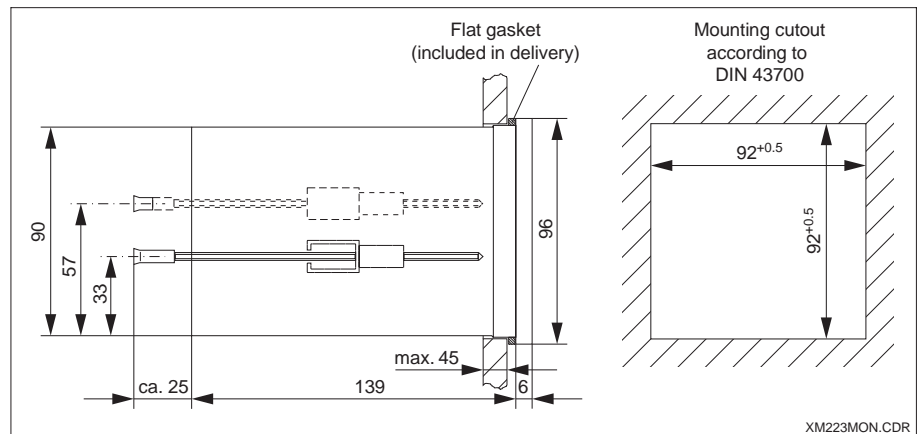

Installation of panel-mounted housing

XM223MON.CDR

Mounting of Liquisys M CUM 253

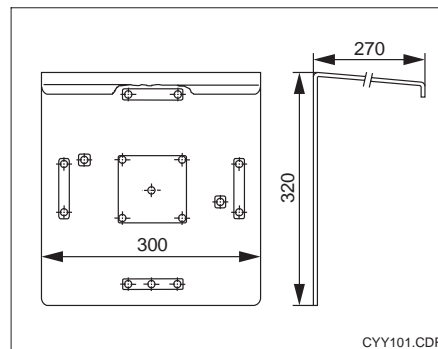

Weather protection cover CYY 101 (see Accessories)

CYY101.CDR

There are several mounting options for the field instrument:

- Mounting on a square-tube mounting post
- Mounting on cylindrical pipes
- Wall mounting with fastening screws

Weather protection cover CYY 101 is required for outdoor installation. This cover is compatible with all field instrument mounting options.

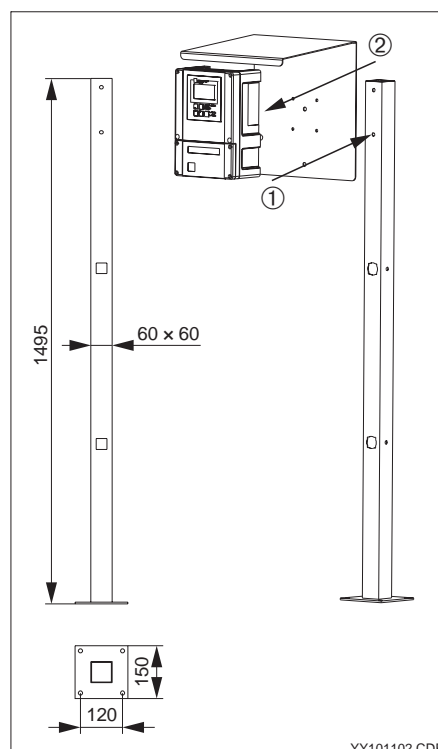

Universal upright post CYY 102 or identical upright post of suspension assembly holder CYH 101 (square tube, see Accessories); mounting of weather protection cover and field instrument

YY101102.CDR

Proceed as follows to install the instrument on a square-tube mounting post (universal upright post CYY 102 or upright post of suspension assembly holder CYH 101):

- ① Install the weather protection cover on the upright post first.
- ② Attach the field instrument to the weather protection cover from the rear.

Mounting of Liquisys M CUM 253 (continued)

Post mounting kit for installation of field housing on cylindrical pipes (horizontal or vertical, max. \varnothing 60 mm; see Accessories)

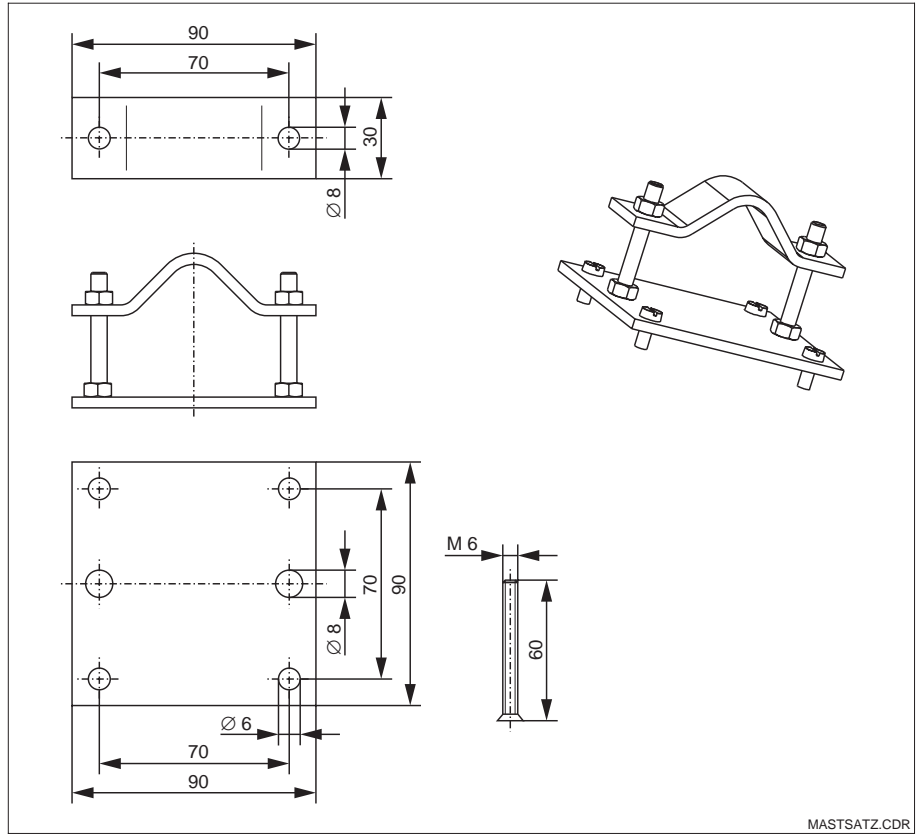

Mounting on cylindrical pipes (shown with weather protection cover installed on right)

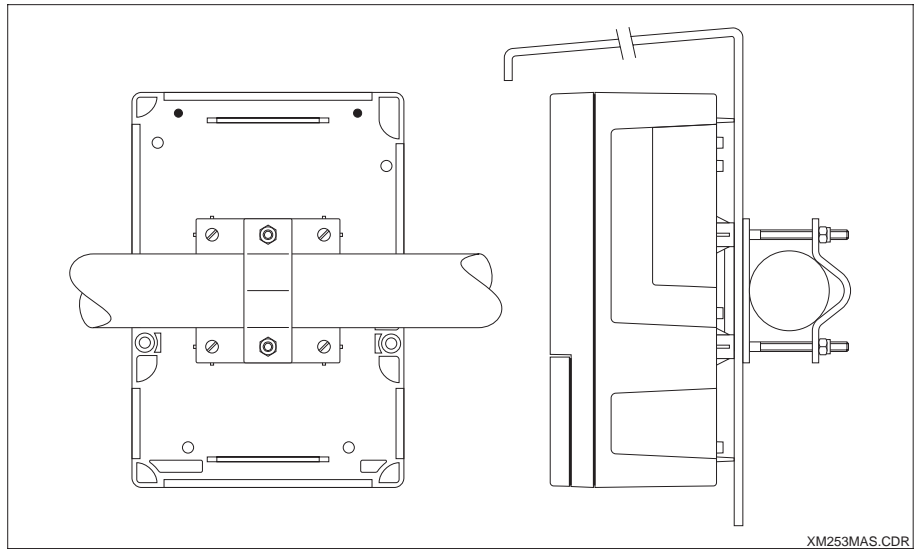

Wall mounting
Screws: \varnothing 6 mm
Anchors: \varnothing 8 mm

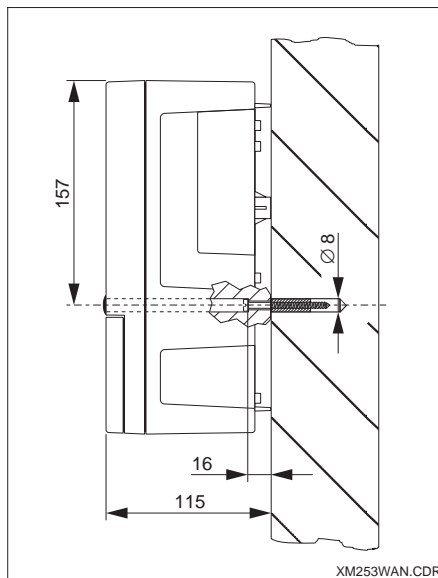

Technical data

General specifications

Manufacturer	Endress+Hauser
Product designation	Liquisys M CUM 223 Liquisys M CUM 253

Operating mode and system design

Measuring principle	A CUS 31 or CUS 41 sensor is connected to the digital sensor interface on the Liquisys M CUM 223 / 253. The sensors supply a standardised signal for turbidity and temperature.
---------------------	---

Input

Measured quantities	turbidity, suspended solids, temperature
---------------------	--

Turbidity measurement with CUS 31

Measuring range	0.000 ... 9999 FNU, 0.00 ... 3000 ppm, 0.0 ... 3.0 g/l, 0.0 ... 200.0%
Turbidity offset range	±99.99 FNU, ±99.99 ppm, ±99.9 g/l, ±99.9%

Suspended solids measurement with CUS 41

Measuring range	0.00 ... 9999 FNU, 0.00 ... 9999 ppm, 0.0 ... 300.0 g/l, 0.0 ... 200.0%
Suspended solids offset range	±99.99 FNU, ±99.99 ppm, ±99.9 g/l, ±99.9%

Temperature measurement

Temperature sensor	NTC, 30 kΩ at 25 °C
Measuring range	-5.0 ... +70.0 °C
Temperature offset range	±5 °C

Signal input for turbidity / suspended solids / temperature

Sensor interface	digital
Max. length of cable to sensor	200 m

Digital inputs 1 and 2

Voltage	10 ... 50 V
Current consumption	max. 10 mA

Output

Signal output for turbidity / suspended solids

Current range	0 / 4 ... 20 mA, galvanically separated; error current 2.4 / 22 mA
Load	max. 500 Ω
Max. resolution	700 digits/mA
Output range	adjustable, min. Δ 0.1 FNU, Δ 1 ppm, Δ 1 g/l, Δ 0.1%
Separation voltage	max. 350 V _{rms} / 500 V DC
Overvoltage (lightning) protection	according to EN 61000-4-5:1995

Signal output for temperature (optional)

Current range	0 / 4 ... 20 mA, galvanically separated
Load	max. 500 Ω
Max. resolution	700 digits/mA
Output range	adjustable, Δ 10 ... Δ 100% of upper range value
Separation voltage	max. 350 V _{rms} / 500 V DC
Overvoltage (lightning) protection	acc. to EN 61000-4-5:1995

Auxiliary voltage output

Output voltage	15 V ± 0.6 V
Output current	max. 10 mA

Contact outputs (potential-free changeover contacts)

Switching current with ohmic load (cos φ = 1)	max. 2 A
Switching current with inductive load (cos φ = 0.4)	max. 2 A
Switching voltage	max. 250 V AC, 30 V DC
Switching power with ohmic load (cos φ = 1)	max. 1250 VA AC, 150 W DC
Switching power with inductive load (cos φ = 0.4)	max. 500 VA AC, 90 W DC

Limit contactor

Pickup / dropout delay	0 ... 7200 s
------------------------	--------------

Technical data (continued)

Output (continued)

Controller

Function (adjustable)	pulse length / pulse frequency controller
Controller response	P, PI, PD, PID
Control gain K_p	0.01 ... 20.00
Integral action time T_n	0.0 ... 999.9 min
Derivative action time T_v	0.0 ... 999.9 min
Period for pulse length controller	0.5 ... 999.9 s
Frequency for pulse frequency controller	60 ... 180 min ⁻¹

Alarm

Function (switchable)	steady / fleeting contact
Alarm threshold adjustment range	turbidity / suspended solids / temperature: complete measuring range
Alarm delay	0 ... 2000 s (min)

Accuracy

Turbidity measurement with CUS 31

Resolution	0.001 FNU, 0.01 ppm, 0.1 g/l, 0.1%
Deviation of indication ¹	±2% of meas. value (min. 0.02 FNU)
Reproducibility ¹	±1% of meas. value (min. 0.01 FNU)
Measurement deviation ¹ , turbidity signal output	1% of current output range (min. 0.02 FNU)

Suspended solids measurement with CUS 41

Resolution	0.01 FNU, 0.01 ppm, 0.1 g/l, 0.1%
Deviation of indication ¹	±2% of meas. value (min. 0.02 FNU)
Reproducibility ¹	±1% of meas. value (min. 0.01 FNU)
Measurement deviation ¹ , suspended solids signal output	1% of current output range (min. 0.02 FNU)

Temperature measurement

Resolution	0.1 °C
Deviation of indication ¹	max. 1.0% of measuring range
Measurement deviation ¹ , temperature signal output	max. 1.25% of current output range

Ambient conditions

Ambient temperature (nominal operating conditions)	-10 ... +55 °C
Ambient temperature (limit operating conditions)	-20 ... +60 °C
Storage and transport temperature	-25 ... +65 °C
Relative humidity (nominal operating conditions)	10 ... 95%, non-condensing
Protection class of panel-mounted unit	IP 54 (front), IP 30 (housing)
Protection class of field housing	IP 65
Electromagnetic compatibility	interference emission and interference immunity acc. to EN 61326-1:1998

Physical data / design

Dimensions of panel-mounted unit (H × W × D)	96 × 96 × 145 mm
Mounting depth	approx. 165 mm
Dimensions of field housing (H × W × D)	247 × 170 × 115 mm
Weight of panel-mounted unit	max. 0.7 kg
Weight with field housing	max. 2.3 kg
Display	LC display, two lines, five and nine digits, with status indicators

Materials

Housing of panel-mounted unit	polycarbonate
Front membrane	polyester, UV-resistant
Field housing	ABS PC Fr

Power requirements

Supply voltage	100 / 115 / 230 V AC +10 / -15%, 48 ... 62 Hz 24 V AC/DC +20 / -15%
Power consumption	max. 7.5 VA
Fuse protection	fine-wire fuse, medium time-lag, 250 V / 3.15 A

¹acc. to IEC 746-1, for nominal operating conditions

Subject to modifications.

Accessories

Mounting accessories

Type	Features	Order number
Weather protection cover CYY 101	For mounting on field housing, for outdoor installation Dimensions (H x W x D): 320 x 300 x 270 mm Material: stainless steel 1.4301	CYY 101-A
Universal upright post CYY 102	Square tube for mounting of field housing Dimensions (H x W x D): 1495 x 60 x 60 mm Material: stainless steel 1.4301	CYY 102-A
Suspension assembly holder CYH 101	For installation on basin or channel rim Materials: stainless steel 1.4301 / PE	CYH 101-D
Pendulum frame	For pendulum suspension of assemblies, e.g. CYA 611 Material: stainless steel 1.4301	50080196
Post mounting kit	Kit for mounting of field housing on horizontal or vertical pipes (Ø max. 60 mm) Material: stainless steel 1.4301	50086842

Assemblies

Type	Features	Applications
DipFit W CYA 611	Immersion assembly with G 1, G ¾ or NPT ¾" thread	Basins and channels
FlowFit W CUA 250	Flow assembly (pressure-resistant up to 6 bar / 20 °C)	Pipelines
CUA 461	Retractable assembly for sensor installation and removal without process interruption (max. 2 bar)	Pipelines

Sensors

Type	Features	Applications
TurbiMax W CUS 31	Turbidity sensor for drinking water and service water applications	Drinking water, filter monitoring, phase separation, surface water
TurbiMax W CUS 41	Sensor for measurement of suspended solids	Sedimentation, sewage treatment plants, industrial service water, phase separation

Cable / junction box

Type	Features	Order number
CYK 8	Data cable (unassembled) for extension of CUS 31 / CUS 41 sensor connection cables	50089633
VBM	Junction box	50003987

Product structure

Turbidity/suspended solids transmitter Liquisys M CUM 223 / CUM 253

Version

- TU Turbidity/suspended solids measurement
- TS Turbidity/suspended solids measurement with additional functions

Power supply

- 0 230 V AC
- 1 115 V AC
- 5 100 V AC
- 8 24 V AC/DC

Measurement output

- 0 Turbidity / SS
- 1 Turbidity / SS and temperature
- 3 Profibus PA
- 5 Turbidity / SS with HART
- 6 Turbidity / SS with HART and temperature

Contacts

- 05 No additional contacts
- 10 2 contacts (limit / P(ID) / timer)
- 15 4 contacts (limit / P(ID) / timer / Chemoclean)
- 16 4 contacts (limit / P(ID) / timer)

CUM 223-				
CUM 253-				

complete order code for CUM 223

complete order code for CUM 253

广州晋合水处理设备有限公司



地 址：广东省广州市海珠区工业大道333号华新园区7幢218
电 话：020-88191905
传 真：020-61139917
邮 编：510300
邮 箱：jinhewater@jinhewater.com
网 址：<http://www.jinhewater.com>

Endress+Hauser 
People for Process Automation