



Level



Pressure



Flow



Temperature



Liquid
Analysis



Registration



Systems
Components



Services



Solutions

Technical Information

Liquisys M CLM223/253

Conductivity/Resistivity Measurement

Transmitter for conductive and inductive sensors



Application

The modular design of the Liquisys M CLM223/253 allows easy adaptation of the transmitter to a variety of customer requirements. Starting with the basic version for "measurement and alarm generation", the transmitter can be equipped with additional software and hardware modules for special applications. These modules can also be retrofitted as required.

Application

- Ultrapure water
- Water treatment
- Ion exchanger, reverse osmosis
- Cooling water desalinisation

Your benefits

- Field or panel-mounted housing
- Universal application
- Simple handling
 - Logically arranged menu structure
 - Ultrasimple two-point calibration
- Safe operation
 - Overvoltage (lightning) protection
 - Direct access for manual contact control
 - User-defined alarm configuration

The basic unit can be extended with:

- 2 or 4 additional contacts for use as:
 - Limit contacts (also for temperature)
 - P(ID) controller
 - Timer for simple rinse processes
 - Complete cleaning with Chemoclean
- Plus package:
 - User defined current output characteristics
 - Automatic cleaning trigger on alarm or limit violation
 - Ultrapure water monitoring acc. to USP (United States Pharmacopeia) and EP (European Pharmacopoeia) (conductive)
 - Polarisation detection (conductive)
 - Concentration measurement
 - Temperature compensation via table
 - Process Check System (PCS): live check of the sensor
 - Adaptive calibration with installation factor (inductive)
- HART® or PROFIBUS-PA/-DP
- 2nd current output for temperature, main measured value or actuating variable
- Current input for flow rate monitoring with controller shut off or for feedforward control

Function and system design

Features of the basic version

Conductive or inductive

Two instrument versions for measurement with conductive (two electrode) sensors or inductive sensors are available. The use of inductive sensors that are less sensitive to soiling than conductive sensors is recommended for high conductivity measurement, concentration measurement or adhering media.

Measuring of conductivity and resistivity (conductive)

This is selected via the menu. During measurement, the value measured can be displayed in the other measuring mode. The temperature is displayed at the same time or, if desired, not shown at all.

Temperature compensation

The following temperature compensation selections are available:

- Linear
- NaCl curve according to IEC 746
- Ultrapure water NaCl (neutral compensation)
- Ultrapure water HCl (acid compensation, also ammonia)

The **reference temperature** is user defined, the standard value is 25 °C (77 °F).

Configuration

Different alarms are required depending on application and operator. Therefore the transmitter permits independent **configuration of the alarm contact and error current** for each individual error. Unnecessary or undesirable alarms can be suppressed in this manner. **Up to four contacts** can be used as limit contacts (also for temperature), to implement a P(ID) controller or for cleaning functions.

Direct **manual operation of the contacts** (bypassing the menu) provides quick access to limit, control or cleaning contacts, permitting speedy correction of deviations.

The **serial numbers** of the instrument and modules and the order code can be called up on the display.

The cell constant can be edited and even **calibrated** for demanding special applications.

Additional functions of the plus package

Current output configuration

In order to output wide measuring ranges while still achieving a high resolution in specific ranges, the **current output** can be configured as required via a table. This permits **bilinear** or **quasi-logarithmic** curves, etc.

Polarisation detection

Polarisation effects in the boundary layer between the sensor and the medium to be measured limit the measuring range of conductive conductivity sensors.

The transmitter can detect polarisation effects using an innovative, intelligent signal evaluation process.

Process Check System (PCS)

This function checks the measuring signal for stagnation. If the measuring signal does not change for some time (several measured values), an alarm is triggered. Soiling, blockage or similar could be the cause of such behaviour.

Ultrapure water monitoring acc. to USP (United States Pharmacopeia) and EP (European Pharmacopoeia)

Ultrapure water monitoring according to USP <645> and EP means that the uncompensated conductivity and the temperature are measured and compared to a table.

The transmitter (conductive with additional contacts) comes with the following functions:

- Monitoring of "Water for Injection" (WFI) according to USP and EP
- Monitoring of "Highly Purified Water" (HPW) according to EP
- Monitoring of "Purified Water" (PW) according to EP

The **user-adjustable pre-alarm** indicates undesirable operating values in due time. Full compliance with USP or EP requires the use of a precisely calibrated sensor, for example, the CLS16.

Concentration measuring

The conversion from conductivity to concentration is effected using four user-definable **concentration curves**. This permits concentrations to be displayed in %, ppm, mg/l or TDS (total dissolved solids).

Adaptive calibration for determination of the installation factor (inductive)

Inductive measuring sensors must normally be installed in pipes at a required minimum distance from the pipe wall. If this minimum distance is not observed, the measured value changes. The built-in adaptive calibration using the **installation factor** allows you to compensate for this once the sensor is installed.

Second current output

The second current output can be configured for temperature, main measured value (conductivity, resistivity, concentration) or actuating variable.

Current input

The current input of the transmitter allows two different applications: controller shut-down in case of lower flow rate violation or total failure in the main flow as well as feedforward control. Both functions are also combinable.

Explosion proof versions for zone 2

Application of transmitter and sensor in hazardous area zone 2

Field housing CLM253 with power supply 24 V

Application of transmitter as related electrical equipment in non-hazardous area or in simple pressurised apparatus; application of sensor in hazardous area zone 2

Field housing CLM253 with power supply 230 V or
Panel mounted housing CLM223 with power supply 230 V or 24 V

Remarks:

- Permissible sensors: all conductive conductivity sensors, inductive sensors CLS50 (Non-Ex version) and CLS52.
- Do not use blue sensor cables. Electric circuits are not intrinsically safe according to EN 50039.

Measuring system

A complete measuring systems comprises:

- The transmitter Liquisys M CLM223 or CLM253
- A sensor with or without an integrated temperature sensor
- A measuring cable CYK71 (conductive), CPK9 for Condumax H CLS16 or CLK5 (inductive)

Options: extension cable, junction box VBM

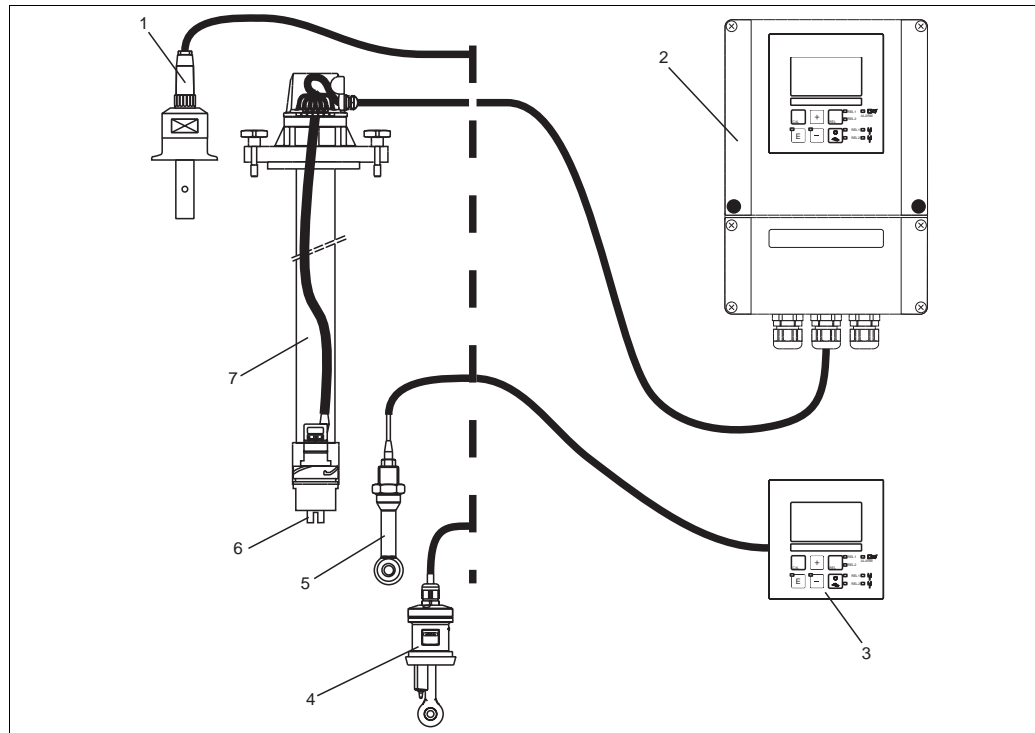

C07-CLM2x3xx-14-06-00-xx-001.eps

Complete measuring system Liquisys M CLM223/253

- 1 Conductive sensor CLS15
 2 Liquisys M CLM253
 3 Liquisys M CLM223
 4 Inductive sensor CLS52

- 5 Inductive sensor CLS50
 6 Conductive sensor CLS21
 7 Immersion assembly CLA111

Input

Measured variables	Conductivity, resistivity, temperature	
Measuring range	Conductivity (conductive): Conductivity (inductive): Resistivity: Concentration: Temperature:	0 ... 60 mS/cm (uncompensated) 0 ... 2000 mS/cm (uncompensated) 0 ... 200 M Ω ·cm 0 ... 9999 (% , ppm, mg/l, TDS) -35 ... +250 °C (-31 ... +482 °F)
Cable specification	Cable length (conductive): Cable length (inductive): Cable resistance CYK71:	conductivity: max. 100 m (328.1 ft) (CYK71) resistivity: max 15 m (49.22 ft) (CYK71) max 55 m (180.46 ft) (CLK5) 165 Ω /km (conductivity measurement)
Cell constant	Adjustable cell constant:	k = 0.0025 ... 99.99 cm ⁻¹
Temperature sensors	Pt 100, Pt 1000, NTC 30K	
Measuring frequency	Conductivity, resistivity (conductive): Conductivity (inductive):	170 Hz ... 2 kHz 2 kHz
Binary inputs	Voltage: Power consumption:	10 ... 50 V max. 10 mA
Current input	4 ... 20 mA, galvanically separated Load: 260 Ω at 20 mA (voltage drop 5.2 V)	

Output

Current range	0/4 ... 20 mA, galvanically separated, active	
Error current	2.4 or 22 mA in case of an error	
Load	maximum 500 Ω	
Linearisation transmission behaviour	Conductivity: Resistivity: Concentration: Actuating variable: Temperature:	adjustable adjustable adjustable adjustable adjustable
Resolution	max. 700 digits/mA	

Min. distance for 0 / 4 ... 20 mA signal	Conductivity:	
	Measured value 0 ... 1.999 $\mu\text{S}/\text{cm}$	0.2 $\mu\text{S}/\text{cm}$
	Measured value 0 ... 19.99 $\mu\text{S}/\text{cm}$	2 $\mu\text{S}/\text{cm}$
	Measured value 20 ... 199.9 $\mu\text{S}/\text{cm}$	20 $\mu\text{S}/\text{cm}$
	Measured value 200 ... 1999 $\mu\text{S}/\text{cm}$	200 $\mu\text{S}/\text{cm}$
	Measured value 2 ... 19.99 mS/cm	2 mS/cm
	Measured value 20 ... 2000 mS/cm	20 mS/cm
	Resistivity	
	Measured value 0 ... 199.9 $\text{k}\Omega\cdot\text{cm}$	20 $\text{k}\Omega\cdot\text{cm}$
	Measured value 200 ... 1999 $\text{k}\Omega\cdot\text{cm}$	200 $\text{k}\Omega\cdot\text{cm}$
Measured value 2 ... 19.99 $\text{M}\Omega\cdot\text{cm}$	2.0 $\text{M}\Omega\cdot\text{cm}$	
Measured value 20 ... 200 $\text{M}\Omega\cdot\text{cm}$	20 $\text{M}\Omega\cdot\text{cm}$	
Concentration	no minimum distance	
Temperature	15 °C	
Isolation voltage	max. 350 V_{RMS} /500 V DC	
Overvoltage protection	according to EN 61000-4-5	
Auxiliary voltage output	Output voltage:	15 V \pm 0.6
	Output current:	max. 10 mA
Contact outputs	Switching current with ohmic load ($\cos \varphi = 1$):	max. 2 A
	Switching current with inductive load ($\cos \varphi = 0.4$):	max. 2 A
	Switching voltage:	max. 250 V AC, 30 V DC
	Switching power with ohmic load ($\cos \varphi = 1$):	max. 500 VA AC, 60 W DC
	Switching power with inductive load ($\cos \varphi = 0.4$):	max. 500 VA AC, 60 W DC
Limit contactor	Pickup/dropout delay:	0 ... 2000 s
Controller	Function (adjustable):	pulse length/pulse frequency controller
	Controller response:	PID
	Control gain K_p :	0.01 ... 20.00
	Integral action time T_n :	0.0 ... 999.9 min
	Derivative action time T_v :	0.0 ... 999.9 min
	Period for pulse length controller:	0.5 ... 999.9 s
	Frequency for pulse frequency controller:	60 ... 180 min^{-1}
	Basic load:	0 ... 40% of max. set value
Alarm	Function (selectable):	Latching/momentary contact
	Alarm threshold adjustment range:	Conductivity, resistivity, concentration, temperature, USP, EP: complete measuring range
	Alarm delay:	0 ... 2000 s (min)

Power supply

Electrical connection

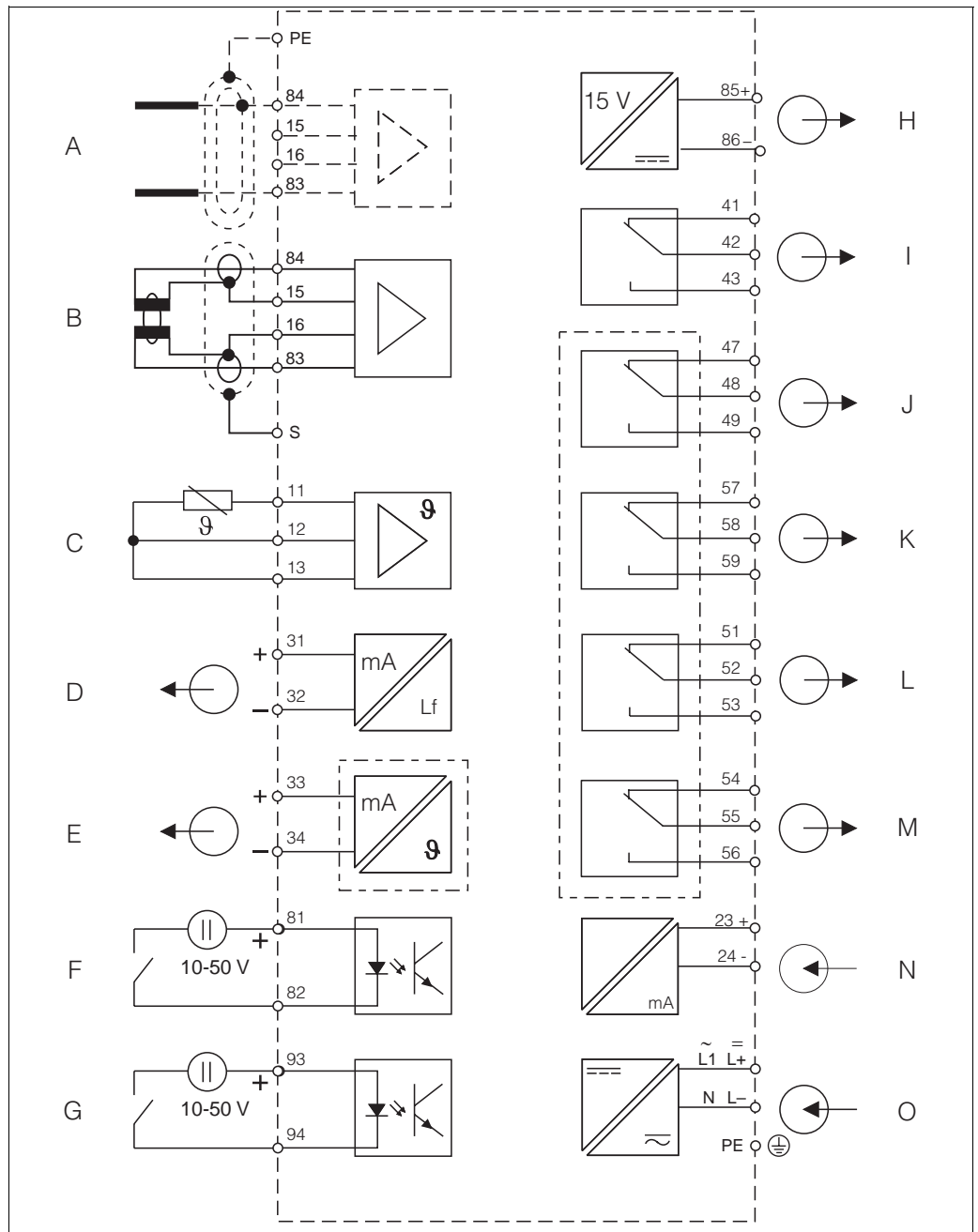

Electrical connection of the transmitter

- | | | | |
|---|------------------------------|---|---|
| A | Sensor (conductive) | I | Alarm (current-free contact position) |
| B | Sensor (inductive) | J | Relay 1 (current-free contact position) |
| C | Temperature sensor | K | Relay 2 (current-free contact position) |
| D | Signal output 1 conductivity | L | Relay 3 (current-free contact position) |
| E | Signal output 2 variable | M | Relay 4 (current-free contact position) |
| F | Binary input 1 (Hold) | N | Current input 4 ... 20 mA |
| G | Binary input 2 (Chemoclean) | O | Power supply |
| H | Aux. voltage output | | |

The instrument has protection class II and is generally operated without protective earth connection. To ensure the measuring stability and the function for conductive sensors you have to connect the outer screen of the sensor cable to the PE terminal.

Connection of sensor

You require screened special measuring cables to connect conductivity sensors to the transmitter. To extend the measuring cable, use junction box and extension cable (see accessories).

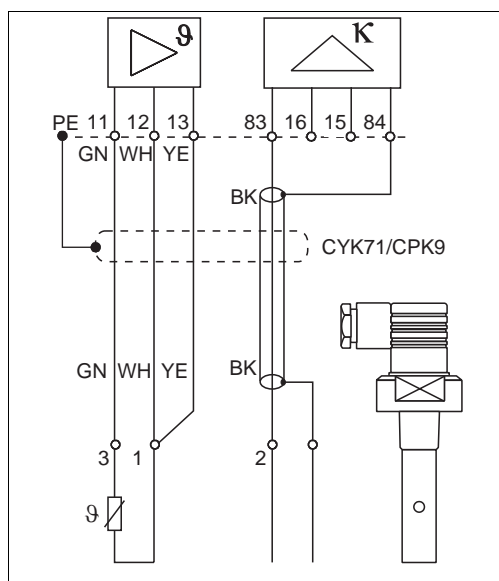

C07-CLM2x3xx-04-06-00-xx-007.eps

Connection of conductive sensors

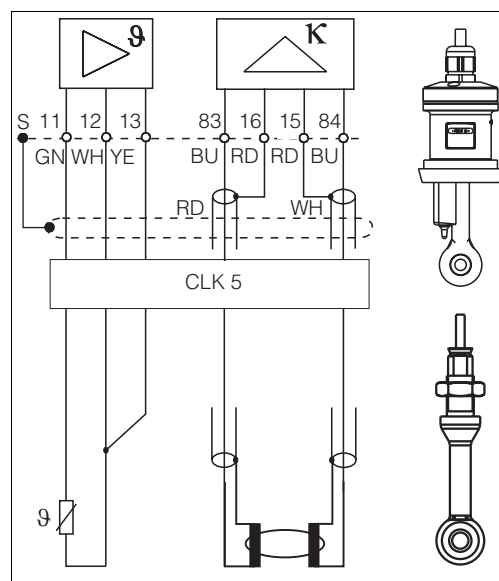

C07-CLM2x3xx-04-06-00-xx-008.eps

Connection of inductive sensors

Power supply

Depending on ordered version:
100/115/230 V AC +10/-15 %, 48 ... 62 Hz
24 V AC/DC +20/-15 %

Power consumption

max. 7.5 VA

Mains protection

Fine-wire fuse, medium-slow blow 250 V/3.15 A

Performance characteristic**Resolution**

Conductivity: depending on the measuring range: 0.001 $\mu\text{S}/\text{cm}$ to 1.999 $\mu\text{S}/\text{cm}$ and $k \leq 0.5 \text{ cm}^{-1}$
Temperature: 0.1 $^{\circ}\text{C}$

Deviation of indication^a

Conductivity:
Display: max. 0.5 % of measured value \pm 4 digits
Conductivity signal output: max. 0.75 % of current output range
Resistivity:
Display: max. 0.5 % of measured value \pm 4 digits
Resistivity signal output: max. 0.75 % of current output range
Temperature:
Display: max. 1.0 % of measuring range
Temperature signal output: max. 1.25 % of current output range

Repeatability^a

Conductivity: max. 0.2 % of measured value \pm 2 digits
Resistivity: max. 0.2 % of measured value \pm 2 digits

Temperature compensation

Range: -35 ... +250 $^{\circ}\text{C}$ (-31 ... +482 $^{\circ}\text{F}$)
Types of compensation: uncompensated, linear, NaCl, table;
conductive only: ultrapure water NaCl, ultrapure water HCl

Reference temperature

25 $^{\circ}\text{C}$ (77 $^{\circ}\text{F}$); adjustable for the compensation of the medium temperature

Temperature offset

± 5 $^{\circ}\text{C}$; for the adjustment of the temperature display

a) acc. to IEC 746-1, for nominal operating conditions

Environment

Ambient temperature	-10 ... +55 °C (+14 ... +131 °F)	
Ambient temperature limit	-20 ... +60 °C (-4 ... +140 °F)	
Storage and transport temperature	-25 ... +65 °C (-13 ... +149 °F)	
Electromagnetic compatibility	Interference emission and interference immunity acc. to EN 61326: 1997 / A1: 1998	
Ingress protection	Panel mounted instrument: Field instrument:	IP 54 (front), IP 30 (housing) IP 65
Relative humidity	10 ... 95%, non-condensing	

Mechanical construction

Dimensions	Panel mounted instrument: Field instrument:	96 x 96 x 145 mm (3.78 x 3.78 x 5.71 inches) Installation depth: approx. 165 mm (6.50") 247 x 170 x 115 mm (9.72 x 6.69 x 4.53 inches)
Weight	Panel mounted instrument: Field instrument:	max. 0.7 kg (1.5 lb) max. 2.3 kg (5.1 lb)
Materials	Housing of panel mounted instrument: Field housing: Front membrane:	Polycarbonate ABS PC Fr Polyester, UV-resistant
Terminals	Cross section	max. 2.5 mm ²

Human interface

Display elements

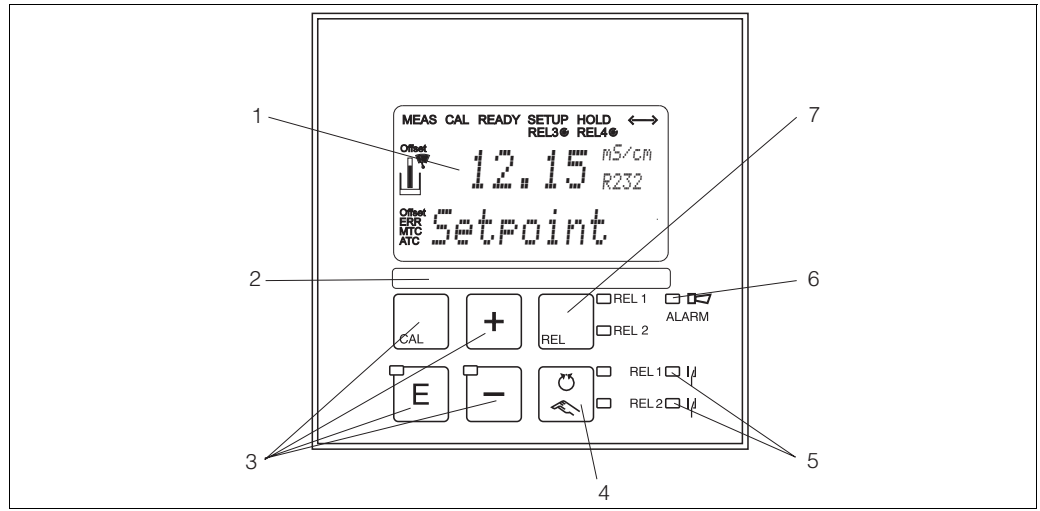

Operating elements

- 1 LC display for display of measured values, configuration data and current menu field
- 2 Field for user labeling
- 3 4 main control keys for calibration and instrument configuration
- 4 Key for switching between automatic/manual operation of the relays
- 5 LED indicators for limit contactor relay (switch status)
- 6 LED indicator for alarm function
- 7 Display of active contact and key for relay switching in manual mode

The display simultaneously shows the current measured value and the temperature - the essential process data. Brief information texts in the configuration menu provide assistance with parameter configuration.

Instrument control functions

All instrument control functions are arranged in a logical menu structure. Following access code entry, the individual parameters can be easily selected and modified as needed.

Certificates and approvals

CE symbol

Declaration of conformity

The product meets the legal requirements of the harmonized European standards. The manufacturer confirms compliance with the standards by affixing the CE symbol.

Ex approval for zone 2

Explosion protection for Zone 2

CLM253-..6...	ATEX II 3G EEx nA[L] IIC T4
CLM253-..4...	ATEX II 3G [EEx nAL] IIC
CLM223-..4...	
CLM223-..6...	

Ordering information

Product structure

		Version	
	CD	Conductivity/resistivity measurement (conductive two-electrode sensor)	
	CS	Conductivity/resistivity measurement (conductive two-electrode sensor) with additional functions (Plus package)	
	ID	Conductivity measurement (inductive sensor)	
	IS	Conductivity measurement (inductive sensor) with additional functions (Plus package)	
		Power supply; approval	
	0	230 V AC	
	1	115 V AC	
	2	230 V AC; CSA Gen. Purp.	
	3	115 V AC; CSA Gen. Purp.	
	4	230 V AC; ATEX II 3G [Ex nAL] IIC	
	5	100 V AC	
	6	24 V AC/DC; ATEX II 3G [Ex nAL] IIC for CPM223, Ex nA[L] IIC T4 for CPM253	
	7	24 V AC/DC; CSA Gen. Purp.	
	8	24 V AC/DC	
		Output	
	0	1 x 20 mA, conductivity/resistivity	
	1	2 x 20 mA, conductivity/resistivity and temperature/main measured value/actuating variable	
	3	PROFIBUS PA	
	4	PROFIBUS DP	
	5	1 x 20 mA, conductivity/resistivity HART®	
	6	2 x 20 mA, conductivity/resistivity HART® and temp./main measured value/actuating variable	
		Additional contacts; analogue input	
	05	Not selected	
	10	2 x relay (limit/controller/timer)	
	15	4 x relay (limit/controller/Chemoclean)	
	16	4 x relay (limit/controller/timer)	
	20	2 x relay (limit/controller/timer); current input	
	25	4 x relay with cleaning (limit/controller/timer/Chemoclean); current input	
	26	4 x relay with timer (limit/controller/timer); current input	
CLM253-			
CLM223-			
			complete order code

Additional functions of the Plus package

- Current output table to cover large areas with varying resolution, fields O33x
- Process Check System (PCS): live check of the sensor, function group P
- Ultrapure water monitoring for "Water for injection" (WFI) and "Purified water" (PW) acc. to United States Pharmacopeia (USP) and European Pharmacopoeia (EP) with pre-alarm (conductive, additional contacts necessary), fields R26x and R27x
- Polarisation detection (conductive), function group P
- Concentration measurement, function group K
- Temperature compensation via coefficient table, function group T
- Adaptive calibration with installation factor (inductive), fields C13x
- Automatic cleaning function start, field F8

Scope of delivery

The delivery of the field instrument includes:

- 1 transmitter CLM253
- 1 plug-in screw terminal
- 1 cable gland Pg 7
- 1 cable gland Pg 16 reduced
- 2 cable glands Pg 13.5
- 1 operating instructions BA 193C/07/en
- versions with HART communication:
 - 1 operating instructions Field Communication with HART, BA 208C/07/en
- versions with PROFIBUS communication:
 - 1 operating instructions Field Communication with PROFIBUS PA/DP, BA 209C/07/en
- versions with explosion protection for hazardous area zone II (ATEX II 3G):
 - Safety instructions for use in explosion-hazardous areas, XA 194C/07/a3

The delivery of the panel mounted instrument includes:

- 1 transmitter CLM223
- 1 set of plug-in screw terminals

- 2 tensioning screws
- 1 operating instructions BA 193C/07/en
- versions with HART communication:
 - 1 operating instructions Field Communication with HART, BA 208C/07/en
- versions with PROFIBUS communication:
 - 1 operating instructions Field Communication with PROFIBUS PA/DP, BA 209C/07/en
- versions with explosion protection for hazardous area zone II (ATEX II 3G):
 - Safety instructions for use in explosion-hazardous areas, XA 194C/07/a3

Accessories

Sensors

- Condumax W CLS12
Conductive conductivity sensor for standard, Ex and high temperature applications;
Ordering acc. to version, see Technical Information TI 082/C07/en
- Condumax W CLS13
Conductive conductivity sensor for standard, Ex and high temperature applications;
Ordering acc. to version, see Technical Information TI 083/C07/en
- Condumax W CLS15
Conductive conductivity sensor for pure and ultra-pure water applications (incl. Ex);
Ordering acc. to version, see Technical Information TI 109/C07/en
- Condumax H CLS16
Hygienic conductive conductivity sensor for pure and ultra-pure water applications (incl. Ex);
Ordering acc. to version, see Technical Information TI 227/C07/en
- Condumax W CLS19
Conductive conductivity sensor for pure and ultra-pure water applications;
Ordering acc. to version, see Technical Information TI 110/C07/en
- Condumax W CLS21
Conductive conductivity sensor for applications with middle to high conductivity
(incl. Ex); Ordering acc. to version, see Technical Information TI 085/C07/en
- Indumax P CLS50
Inductive conductivity sensor for standard, Ex and high temperature applications;
Ordering acc. to the sensor version, see Technical Information (TI118C/07/en)
- Indumax H CLS52
Inductive conductivity sensor with short response time in hygienic design;
Ordering acc. to the sensor version, see Technical Information (TI167C/07/en)

广州晋合水处理设备有限公司



地 址：广东省广州市海珠区工业大道333号华新园区7幢218
电 话：020-88191905
传 真：020-61139917
邮 编：510300
邮 箱：jinhewater@jinhewater.com
网 址：<http://www.jinhewater.com>

Endress+Hauser 
People for Process Automation