

Liquids Level Switch *liquiphant® T FTL 260*

**Vibration limit switch for liquids,
maintenance-free alternative to float switches**

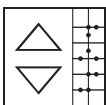
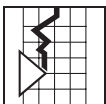
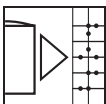

Features and benefits

The Liquiphant T is a compact level switch that is ideal in places where access is difficult or space is limited.

- ï Small, slender design: minimal space requirement, easy mounting
- ï Stainless steel housing: rugged, resist corrosion and harsh environments
- ï Indicates material presence or absence in vessel or pipe: green LED indicates unit operating, red LED indicates switch status
- ï Calibration not required: quick installation, ready to operate
- ï Compensation for process material changes not required: unaffected by material density changes, unaffected by viscosity or conductivity changes

The Liquiphant T is designed to be connected to any AC voltage from 19 to 253 V in series with the control device (e.g. relay, solenoid valve, miniature contactors, etc.) or the DC version (3-wire PNP) which can be used when connecting to programmable logic controllers (PLC).

Applications

The Liquiphant T is an ideal alternative or replacement for low cost float switches, ultrasonic gap switches, conductivity, capacitance and other switch types. It is a level limit switch for liquid level detection in storage tanks, tanks with agitators, and piping.

Endress + Hauser

The Power of Know How



Application

The Liquiphant T can be used as an alternative to float switches as well as in applications where buildup, turbulence, liquid flow and gas bubbles are present.

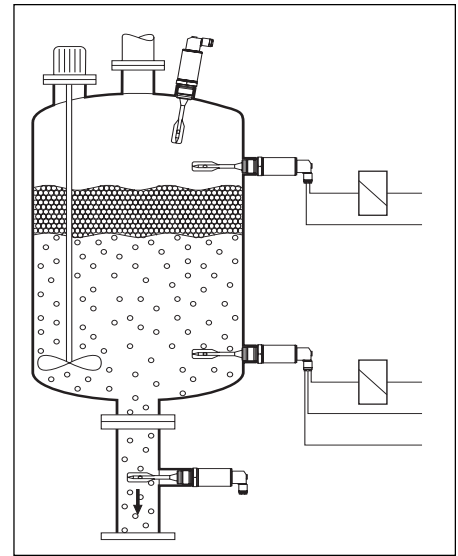

Function

The symmetrical vibrating fork is excited to its resonant frequency which changes when the fork is submerged in liquid. The change in frequency is registered by the electronics, which actuate an electronic switch.

The Liquiphant T can be operated in both minimum or maximum fail-safe mode, i.e. the electronic switch opens on reaching the limit value, in cases of fault or loss of power

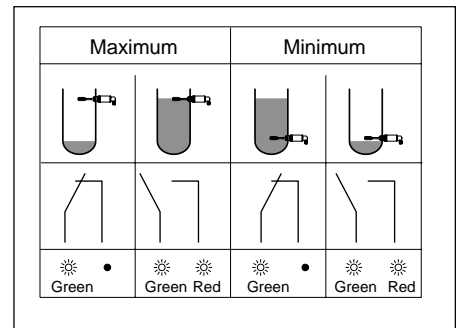
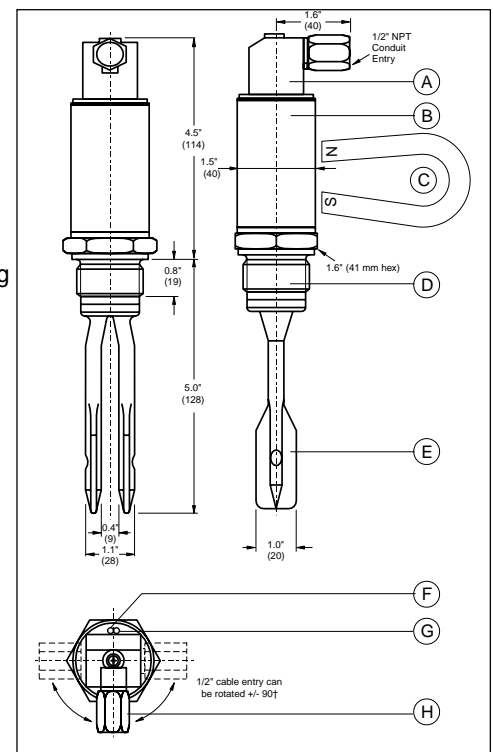

Diagram showing the function of the electronic switch and LED operation depending on the level and fail-safe mode.

Dimensions

- A The fail-safe mode is selected using different connections in the wiring plug
- B The stainless steel housing protects the potted electronics
- C The switching function can be checked by placing a strong magnet on the external portion of the housing
- D Process connection is available in versions to fit most vessels: 1 1/2 NPT, G 1A (parallel thread) and R 1 tapered. Process connections are stainless steel
- E Fork assembly, stainless steel
- F Green LED operating mode indicator
- G Red LED indicates switching mode or circuit open
- H Plug housing can be fitted or rotated $\pm 90^\circ$



Installation guidelines

The Liquiphant T is suitable for vertical or horizontal mounting via flange, nozzle, or pipe. The 1½ NPT threaded body allows simple installation with minimal re-work of the vessel or pipe. Vibration of the forks must not be blocked. If buildup occurs, ensure there is enough distance between the vibrating fork and the tank or pipe wall.

- A Vertical mounting
- B Horizontal mounting
- C Mounting in a 1½ nozzle (A or C for the entire range of viscosities up to 10,000 cSt).
- D Flanged mounting in nozzle (FTL 260 threaded into a blind flange). The nozzle diameter must be a minimum diameter of 2½ and the viscosity a maximum of 2000 cSt.
- E Tightening the FTL 260 with socket spanner tool (see accessories).

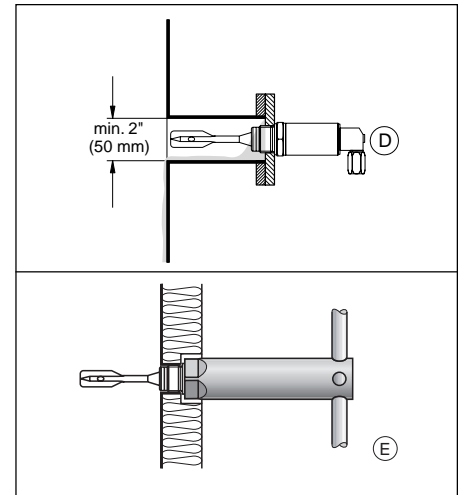
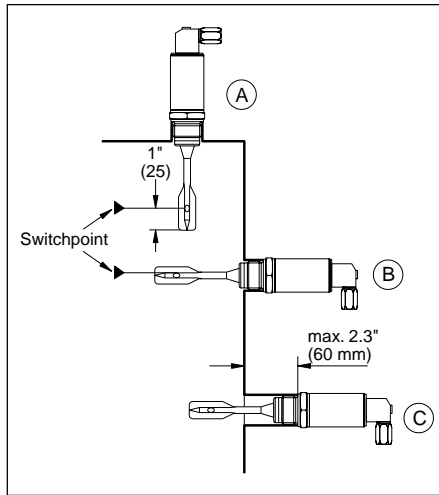

Wiring guidelines

AC Version

A load must be connected in series with the FTL 260. The voltage drop across the FTL 260 in the closed (ON) mode may be up to 12 V. A minimum terminal voltage of 19 V is required for the unit to switch. In the open (OFF) mode, a residual current of 3.8 mA flows.

DC Version

The DC version is recommended when used with programmable logic controllers (PLC).

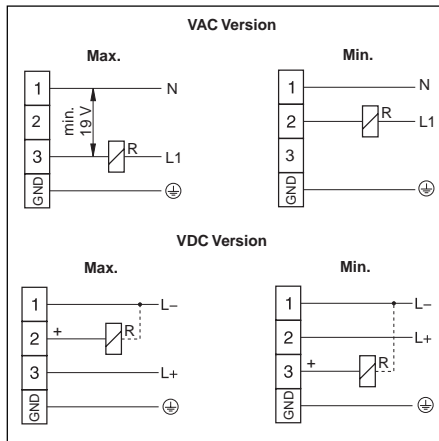

Switch function

Minimum or maximum switch function is dependent on wiring connections. LED and switch function is shown on the previous page. The minimum or maximum setting is shown in the wiring diagram. The load can be an indicator light or relay coil. When the switch is in the iOFFi state, a trickle current flows, not enough to light an indicator or actuate a relay coil. When the switch is in the iONi state, current flow increases to a level that can pull in a relay coil or light a filament bulb.

Technical data

Mechanical construction

Housing	316 SS with plastic terminal housing (PPSU)
Fork assembly	316 SS
Process connections	1½ NPT to ANSI B 1.20.1, 316 SS G 1 A to DIN ISO 228/1, 316 SS R 1 to DIN 2999 Part 1, 316 SS
Electrical connection	4-pole plug connector, 1/2½ NPT conduit entry

Process conditions

Ambient temperature	-40 to +160F (-40 to +70C), refer to chart below
Process temperature	-40 to +300F (-40 to +150C), refer to chart below
Storage temperature	-40 to +185F (-40 to +85C)
Operating pressure	Maximum 360 psi (40 bar), refer to chart below
Maximum viscosity	10,000 cSt
Minimum density	44 lbs/ft³

Temperature Diagram
 T_U = temp. at housing
 T_S = process temp.

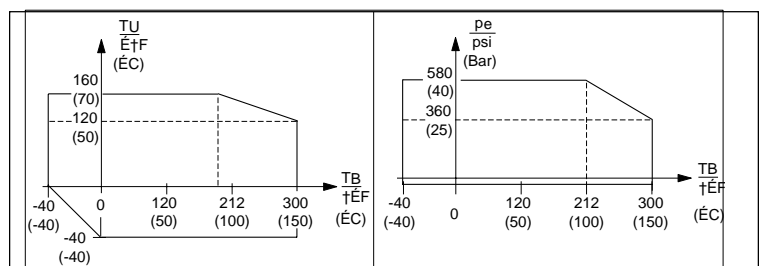

Mechanical construction

AC Input power / Output	AC, 19 to 253 V, 50/60 Hz, 3.8 mA current consumption (stand-by) Connectable load, short term (40 ms) maximum 1.5 A, maximum 375 VA at 250 V or 36 VA at 24 V (no short-circuit protection). Connectable load, continuous, maximum 87 VA at 253 V maximum 8.4 VA at 24 V. Minimum 2.5 VA at 250 V (10 mA) minimum 0.5 VA at 24 V (20 mA). Voltage drop across FTL 260, maximum 12 V. Residual current, maximum 3.8 mA with open thyristor (stand by)
DC Input power / Output	DC, 10 to 55 V, 1.7 V maximum ripple, 0 to 400 Hz, 15 mA maximum current consumption, reverse polarity protection. Connectable load, short term (1 ms), maximum 1 A, maximum 55 V (overload and short-circuit protection). NOTE: The load is switched via PNP transistor. Connectable load, continuous, maximum 350 mA, maximum 0.5 µF at 24 V. Residual voltage < 3 V (with closed transistor). Residual current < 100 µA (with open transistor).
Output function	Fail-safe mode: Minimum or maximum, depending on wiring connections Signal failure: Output open Switching time: Approximately 0.5 s when covered with material, approximately 1.5 s when free of material Hysteresis: Approximately 0.02î (0.4 mm) with vertical mounting
Electromagnetic compatibility	By attaching the CE Mark, Endress+Hauser confirms that the FTL 260 fulfills all legal requirements of the relevant EC directives. Interference immunity to EN 50082-2 (field strength 10 V/m). Interference emission to EN 50081-1.

Accessories

Socket spanner 41 AF for mounting
FTL 260 or FTL 330
Part Number: 942667-0000



Ordering information

FTL 260 -

1	2	3	4
---	---	---	---

- 1 Certificate
 - 0 For non-hazardous areas
 - 3 CSA General Purpose
- 2 Process connection
 - 1 1î NPT thread, 316Ti SS
- 3 Signal output
 - 1 Switch, 2-wire, 19 to 253 VAC
 - 2 Switch, 3-wire PNP, 10 to 55 VDC
- 4 Version
 - 2 15 ft. cable (5 m), NEMA 6P
 - 4 1/2î NPT plug, ISO 4400, NEMA 4X

For application and selection assistance,
in the U.S. call 888-ENDRESS

For total support of your installed base, 24 hours
a day, in the U.S. call 800-642-8737

Visit us on our web site, www.us.endress.com

United States

Endress+Hauser, Inc.
2350 Endress Place
Greenwood, IN 46143
Phone: (317) 535-7138
888-ENDRESS
FAX: (317) 535-8498

Canada

Endress+Hauser
Canada Ltd.
1440 Grahamís Lane
Unit 1, Burlington
ON, L7S 1W3
Phone: (905) 681-9292
800-668-3199
FAX: (905) 681-9444

Mexico

Endress+Hauser
Paseo del Pedregal No. 610
Col. Jardines del Pedregal
01900, Mexico D.F.
Mexico
Phone: (525) 568-2405
FAX: (525) 568-7459

Endress+Hauser
The Power of Know How



广州晋合水处理设备有限公司



地 址：广东省广州市海珠区工业大道333号华新园区7幢218
电 话：020-88191905
传 真：020-61139917
邮 编：510300
邮 箱：jinhewater@jinhewater.com
网 址：<http://www.jinhewater.com>

Endress+Hauser 
People for Process Automation