

Flow Assembly for free Chlorine Chlorine dioxide, pH and Redox *Flow FitW CCA 250*

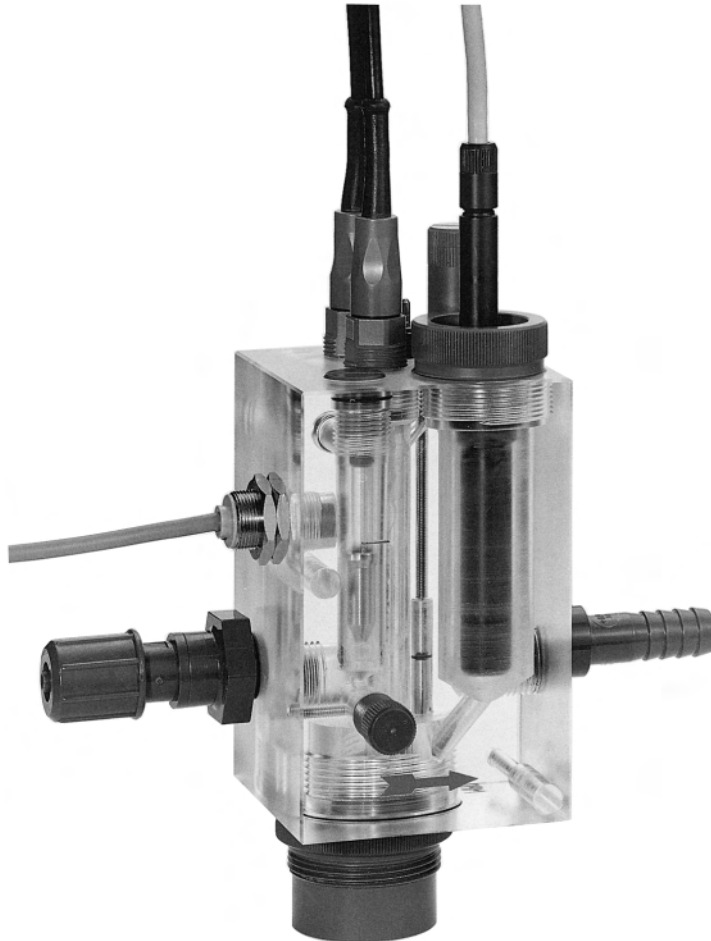

The flow assembly CCA 250 has been specially designed to hold the chlorine sensors CCS 140 or CCS 141 or the chlorine dioxide sensors CCS 240 or CCS 241. Additionally there are 2 mounting positions for one pH electrode and one Redox electrode (e.g. type CPS 31-1EC2ESA and CPS 12-OPA2ESA).

Features and benefits

- The plexiglass body contains a needle valve to adjust the flow of the measured water and a flow meter for optical control of the minimum flow.
- When used with Liquisys or PoolPAC (combined instrument for pH, Redox, chlorine and temperature) a flow alarm can be activated, using an inductive proximity switch.
- A "flow-alarm" is also possible by using a separate proximity switch, type INS-R.
- A potential matching pin is built into the assembly for pH and redox measurement.
- Calibration of pH and redox electrodes is possible without electrode removal. The cap screwed onto the assembly from below can be used as a calibration cup.

Areas of application

- Swimming pool water
- Industrial water
- Drinking water
- Other process applications

Quality made by
Endress+Hauser



ISO 9001

Endress+Hauser

The Power of Know How



Measuring system

The complete measuring system consists of the CCA 250 assembly and:

- Sensors for free chlorine CCS 140 or CCS 141 or sensors for chlorine dioxide CCS 240 or CCS 241
- Transmitter Liquisys M CCM 223/253 or Transmitter PoolPAC CCM 360
- Compact chlorine system CCE 1 / CCE 3
- pH and redox electrodes
- RC-link for PM connection

Dimensions

Dimensions of CCA 250

- 1 Chlorine sensor CCS 140 / 141 or chlorine dioxide sensor CCS 240 / 241
- 2 Measuring chamber for chlorine measuring cell
- 3 Inductive proximity switch for automatic flow control (option)
- 4 Stainless steel flow meter for optical control of minimum flow 30 l/h
- 5 Inlet
- 6 Needle valve for flowrate regulation < 120 l/h
- 7 Outlet
- 8 Measuring chamber for pH / redox electrode
- 9 Closing cap with calibration cup
- 10 Cup (measuring chamber) for cleaning and calibration of pH or redox electrode
- 11 Cup side
- 12 Closing side
- 13 Venting screw
- 14 Connection potential matching PM
- 15 Mounting position for one pH and one redox electrode

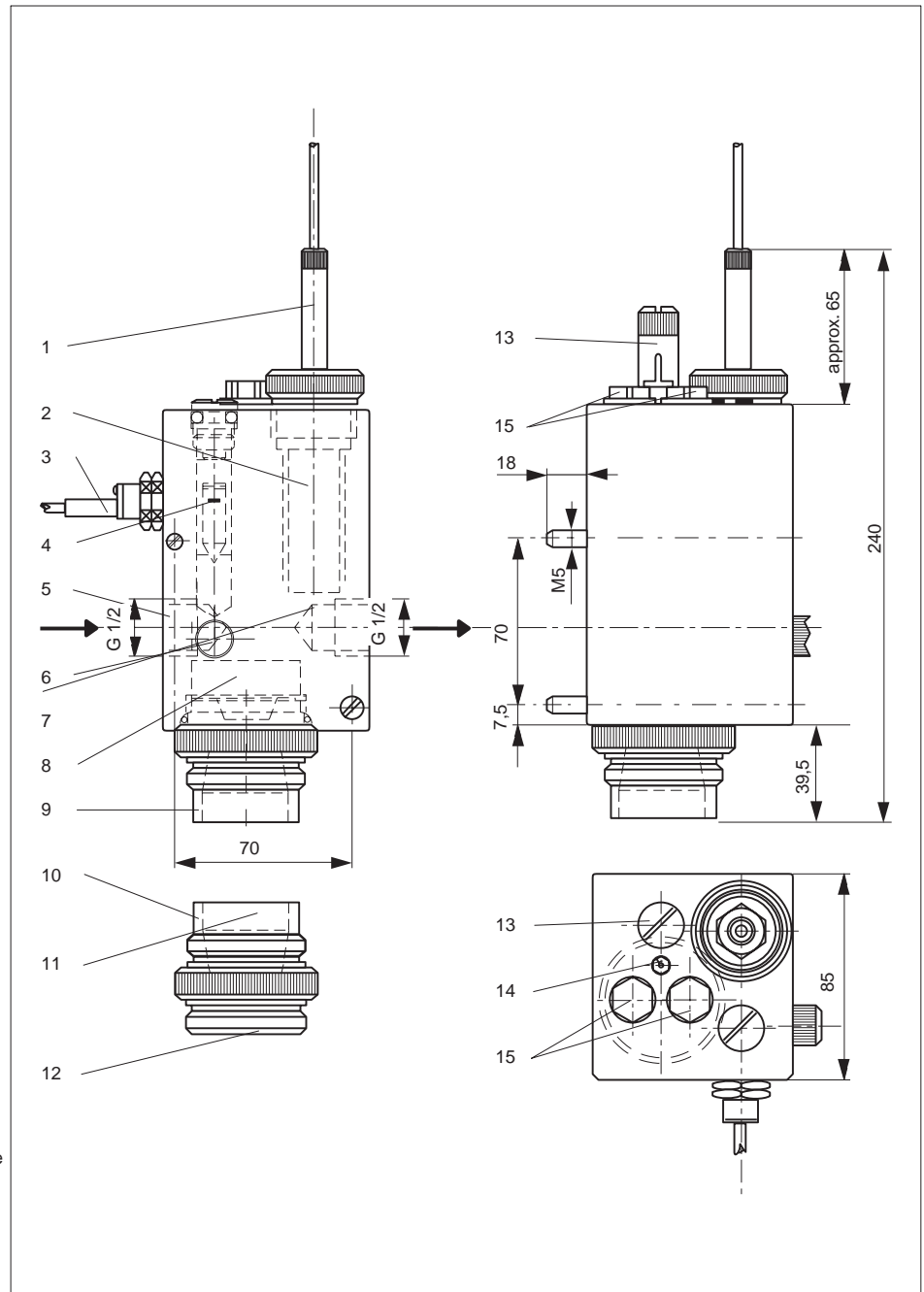

Technical data

General data

Manufacturer	Endress+Hauser GmbH+Co.
Designation	FlowFit W CCA 250

Dimensions

Instrument with electrodes	85 x 85 x 250 mm
----------------------------	------------------

Materials

Measuring cell body	Plexiglass (PMMA), PVC, stainless steel 1.4571, EPDM
---------------------	--

Process connection

Screwed thread for pH and redox electrode	2 x Pg 13.5
Water inlet, outlet	G ½ internal thread
Pipe connection	NV ½ for change-over from G ½ internal thread to bonded adapter coupling for bonding of PVC pipe (OD=16mm)
Hose connection	SV ½ for change-over from G ½ internal thread to hose adapter D 6/12 in inlet and hose adapter D 16 in outlet

Mounting positions

Mounting position chlorine or chlorine dioxide sensor	CCS 140 / CCS 141 or CCS 240 / CCS 241
2 mounting positions for electrodes with Pg 13.5 thread	1 pH electrode (e.g CPS 31-1EC2ESA) and 1 Redox electrode (e.g CPS 12-0PA2ESA)
optional	1 inductive proximity switch

Operating data

Max. permissible water pressure	4 bar without sensors, 1 bar with sensors (at 40°C)
Max. permissible water back pressure	1 bar (at 40 °C)
Min. pressure difference	0.1 bar
Measured water flow (adjustable needle valve)	30 ... 120 l/h
Max. operating temperature	45°C

Subject to modifications

How to order

Flow assembly FlowFit W CCA 250

Adapter

- A Without adapter
- B 2 adapters NV ½ for pipe OD 16
- C 2 adapters D 6/12
- F Adapter D 6/12 and D 16

Version

- 0 Standard
- 1 With inductive proximity switch

CCA 250 -

--	--

← complete order code

Documentation

Technical Information:

<input type="checkbox"/>	Sensors for free chlorine CCS 141 / 141	50028816
<input type="checkbox"/>	Sensors for chlorine dioxide CCS 240 / 241	50068514
<input type="checkbox"/>	Compact chlorine system CCE 1 / CCE 3	50050696
<input type="checkbox"/>	Liquisys M CCM 223/253	51500281
<input type="checkbox"/>	Combined measuring instrument PoolPAC CCM 360	50028589
<input type="checkbox"/>	Microprocessor photometer for chlorine and chlorine dioxide detection CCM 181	50068528
<input type="checkbox"/>	Microprocessor photometer for chlorine CCM 182	51507557

Accessories

- INS**
Inductive proximity switch
for CCA 250 assembly
for flow monitoring
Order No. 50005179
- SV ½**
2 adapters D6/12 and D16 for
CCA 250 for hose connection
Order No. 50003232
- SV ½**
2 adapters D 6/12 for CCA 250
for hose connection
Order No. 50003230
- NV ½**
2 adapters OD 16 for CCA 250
for hose connection
Order No. 5003228
- Pressure reducer**
with connection G ½ and dirt trap,
pre-pressure max. 25 bar,
back pressure 1,5 - 12 bar
Order No. 50046134
- VBC**
Junction box for CMK sensor cable
for cable extension.
Ingress protection IP 65.
Order No. 50005181
- CMK**
Special measuring cable for chlorine
sensors CCS 140 / 141 or chlorine
dioxide sensors CCS 240 / 241 for
cable extension to transmitter.
Price per metre.
Order No. 50005374
- DFS-PAL**
Flow assembly for pH / mV electrodes
Order No. 50043049

广州晋合水处理设备有限公司



地 址：广东省广州市海珠区工业大道333号华新园区7幢218

电 话：020-88191905

传 真：020-61139917

邮 编：510300

邮 箱：jinhewater@jinhewater.com

网 址：<http://www.jinhewater.com>

Endress+Hauser 
People for Process Automation