



Level



Pressure



Flow



Temperature



Liquid
Analysis



Registration



Systems
Components



Services



Solutions

Technical Information

Cerage1 CPS72 / CPS72D

ORP electrodes, analog and digital with Memosens technology
With double junction reference system and integrated bridge electrolyte
for process technology, hygienic and sterile applications



Application

- Hygienic and sterile applications (sterilisable, autoclavable)
 - Fermenters
 - Biotechnology
 - Pharmaceutical industry
 - Food industry
- Process technology and monitoring of processes with:
 - Quickly changing redox potential
 - High proportion of electrode poisons such as H₂S



With ATEX, FM¹ and CSA¹ approval
for application in hazardous areas

Your benefits

- Suitable for CIP / SIP cleaning and autoclavable maintaining high accuracy
- Completely free of acrylamide
- Long-term stable electrode with double junction reference system
 - Protected reference lead
 - Extremely long diffusion path for electrode poisons
 - Short response time due to ceramic diaphragm
- Integrated bridge electrolyte
 - Effective and stable contact of diaphragm and reference lead
 - Insensitive to temperature and pressure changes

Further benefits offered by Memosens technology

- Maximum process safety through contactless inductive signal transmission
- Data safety through digital data transmission
- Easy handling due to storage of sensor-specific data
- Predictive maintenance possible thanks to registration of sensor load data

¹ approval for digital sensors pending

Function and system design

Measuring principle

Redox measurement

The redox potential is a unit of measurement for the state of equilibria between oxidising and reducing components of a medium. Redox potential is measured similarly to the pH value. A platinum or gold electrode is used instead of pH-sensitive membrane glass. Analog to the pH measurement, an integrated Ag/AgCl reference system is used as a reference electrode.

General properties

■ Short response time

The double junction reference system enables short response times as the electrolyte has stable contact with the diaphragm and the ceramic diaphragm allows sufficiently fast diffusion.

■ Insensitive to temperature and pressure changes

Thanks to the new composition of its integrated bridge electrolyte, the electrode is insensitive to temperature and pressure variation.

■ Sterilisable

The electrode is sterilisable and autoclavable (max. 135 °C / 275 °F).

Important properties of CPS72D

Maximum process safety

The inductive and non-contacting measured value transmission of Memosens guarantees maximum process safety and offers the following benefits:

- All problems caused by moisture are eliminated.
 - The plug-in connection is free from corrosion.
 - Measured value distortion from moisture is not possible.
 - The plug-in system can even be connected under water.
- The transmitter is galvanically decoupled from the medium. The result: No more need to ask about "symmetrically high-impedance" or "unsymmetrical" or an impedance converter.
- EMC safety is guaranteed by screening measures for the digital measured value transmission.

Data safety through digital data transfer

The Memosens technology digitalizes the measured value in the sensor and transfers it to the transmitter via a contactless connection. The result:

- An automatic error message is generated if the sensor fails or the connection between sensor and transmitter is interrupted.
- The availability of the measuring point is dramatically increased by immediate error detection.
- The digital signals are suitable for application in hazardous areas; the integrated electronics are intrinsically safe.

Easy handling

Sensors with Memosens technology have integrated electronics that allow for saving calibration data and further information such as total hours of operation and operating hours at very high temperatures. When the sensor is mounted, the calibration data are automatically transferred to the transmitter and used to calculate the current redox potential. Storing the calibration data in the sensor allows for calibration and adjustment away from the measuring point. The result:

- The sensors can be calibrated under optimum external conditions in the measuring lab. Wind and weather do neither affect the calibration quality nor the operator.
- The measuring point availability is dramatically increased by the quick and easy replacement of precalibrated sensors.
- The transmitter does not need to be installed close to the measuring point but can be placed in the control room.
- Maintenance intervals can be defined based on all stored sensor load and calibration data and predictive maintenance is possible.
- The sensor history can be documented on external data carriers and evaluation programs at any time. Thus, the current application of the sensors can be made to depend on their previous history.

Communication with the transmitter

Always connect the digital sensor to a digital transmitter with Memosens technology. Data transmission to an analog transmitter is not possible.

Data storage of CPS72D

Digital sensors are able to store the following system data in the sensor.

- Manufacturing data
 - Serial number
 - Order code
 - Date of manufacture
- Calibration data
 - Calibration date
 - Calibrated offset (operating mode "mV")
 - % slope (operating mode "%")
 - Number of calibrations
 - Serial number of the transmitter used for the last calibration
- Application data
 - Temperature application range
 - Redox application range
 - Date of first commissioning
 - Operating hours

These system data can be displayed with the Mycom S or the Liquiline M CM42 transmitter.

Measuring system

A complete measuring system consists of:

- CPS72 or CPS72D ORP electrode
- Transmitter, e.g. Liquisys M CPM223/253 (with Memosens technology for CPS72D)
- Special measuring cable, e.g. CPK9 or CYK10 Memosens data cable for CPS72D
- Immersion, flow or retractable assembly, e.g. Cleanfit H CPA475

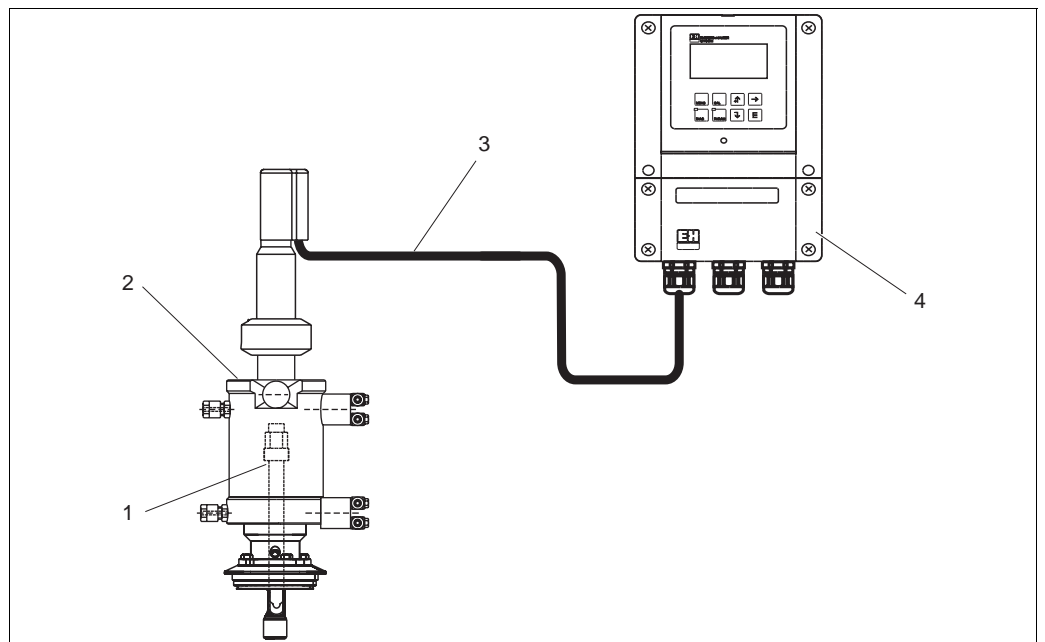

Measuring system for redox measurement

- 1 CPS72 / CPS72D ORP electrode
- 2 Cleanfit H CPA475 assembly
- 3 CPK9 special measuring cable (for electrodes with TOP68 plug-in head) / CYK10 for digital sensors
- 4 Liquisys M CPM253 transmitter

a0003706

Input

Measured variables Redox potential

Measuring range

-1500 ... 1500 mV



Caution!
Please note the process operating conditions.

Installation

Installation instructions

Do not install the electrode upside down. The inclination angle must be at least 15° from the horizontal. A smaller inclination angle is not permitted as such an inclination results in air cushion forming. This might impair the contact of reference and metal lead.



Caution!

- Make sure that the assembly's threaded connection for the electrode is clean and well running before installing the electrode.
- Hand tighten the electrode (3 Nm)! (Given value only applies to installation in Endress+Hauser assemblies.)
- Make sure to follow the installation instructions in the operating instructions of the used assembly.

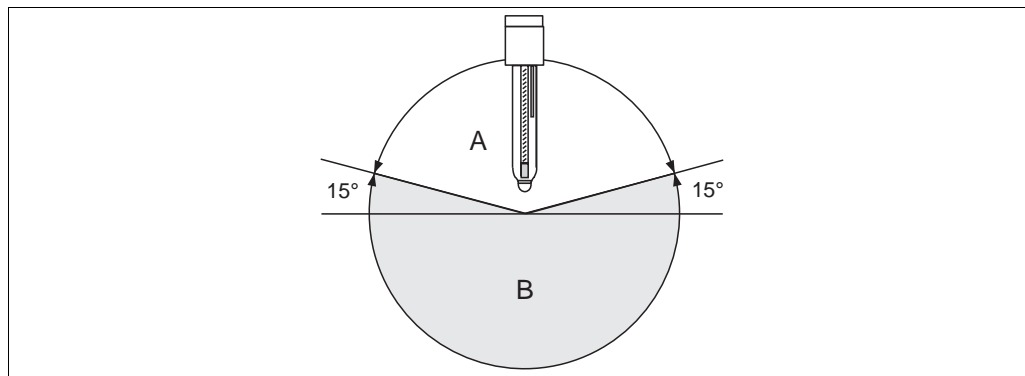

Electrode installation; inclination angle min. 15° from the horizontal

A Permitted inclination angle

B Non-permitted inclination angle

Environment

Ambient temperature



Caution!
Danger of frost damage
Do not use the electrode at temperatures below -15 °C / 5 °F.

Storage temperature

0 ... 50 °C / 32 ... 122 °F

Ingress protection

IP 67: GSA plug-in head (with closed connection system)
IP 68: TOP68 plug-in head (1 m / 3.28 ft water column, 50 °C / 122 °F, 168 h)
IP 68: Memosens plug-in head (10 m / 32.8 ft water column, 25 °C / 77 °F, 45 days, 1 M KCl)

Process

Process temperature -15 ... 135 °C / 5 ... 275 °F

Process pressure 0 ... 10 bar / 0 ... 145 psi

Application



Reducing media, e.g. chromate reduction, chlorine dosing in swimming pools

Caution!

Danger of damage to the electrode

Never use the electrode in applications outside the given specifications!

Mechanical construction

Design, dimensions

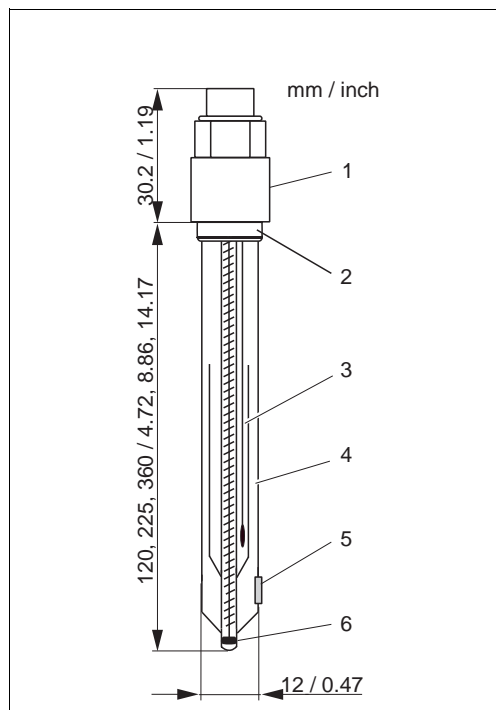

CPS72 with GSA plug-in head

- 1 GSA plug-in head, Pg 13.5
- 2 Viton O-ring with thrust collar
- 3 Ag/AgCl metal lead
- 4 Bridge electrolyte
- 5 Diaphragm
- 6 Platinum ring

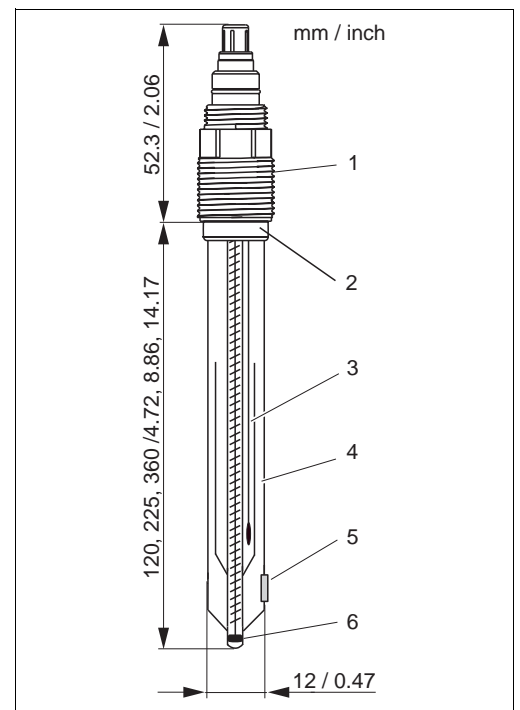

CPS72 with ESA plug-in head

- 1 ESA plug-in head, Pg 13.5
- 2 Viton O-ring with thrust collar
- 3 Ag/AgCl metal lead
- 4 Bridge electrolyte
- 5 Diaphragm
- 6 Platinum ring

Design, dimensions CPS72D

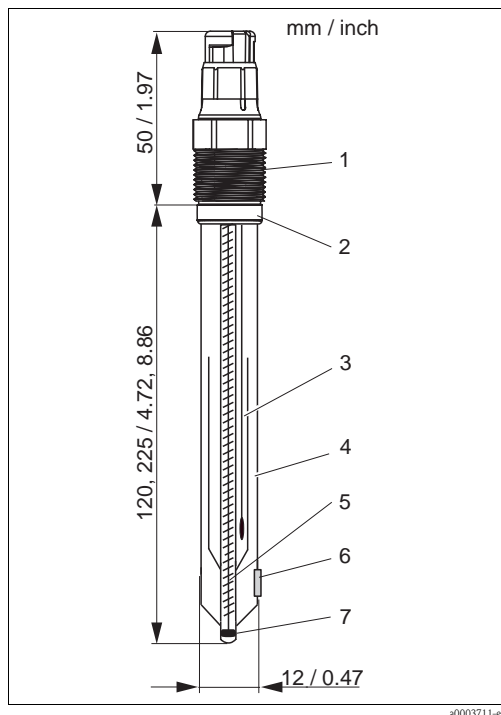

CPS72D with Memosens plug-in head

- 1 Memosens plug-in head
 2 Viton O-ring with thrust collar
 3 Ag/AgCl metal lead
 4 Bridge electrolyte
 5 Diaphragm
 6 Platinum ring

Weight	approx. 0.1 kg / 0.2 lb.	
Material	Electrode shaft	process glass
	Redox measuring element	platinum ring
	Reference lead	Ag/AgCl
	Diaphragm	ceramic, sterilisable
Process connection	Pg 13.5	
Plug-in heads	CPS72: ESA: threaded plug-in head Pg 13.5, TOP 68, 16 bar / 232 psi, Ex GSA: threaded plug-in head Pg 13.5 CPS72D: Memosens plug-in head for digital, contactless data transmission, 16 bar / 232 psi, Ex or non-Ex	
Electrolytes	Advanced Gel 3 M KCl, AgCl free Bridge electrolyte	

Certificates and approvals

Ex approval CPS72 (ESA)

- ATEX II 1G EEx ia IIC T3/T4/T6
- FM Class I Div. 2, in combination with the Liquiline M CM42 and Mycom S CPM153 transmitters

Ex approval CPS72D



- ATEX II 1G EEx ia IIC T3/T4/T6
- FM^a / CSA^a Class I Div. 2, in combination with the Liquiline M CM42 and Mycom S CPM153 transmitters

Note!

Ex versions of digital sensors with Memosens technology are indicated by an orange-red ring in the plug-in head.

Biocompatibility

Biocompatibility validated according to:

- ISO 10993-5:1993
- USP, current revision

TÜV certificate TOP68 and Memosens plug-in heads

Pressure resistance 16 bar, min. triple overpressure safety

Electromagnetic compatibility CPS72D

Interference emission and interference immunity complies with EN 61326: 1997 / A1: 1998

Ordering information

Product structure CPS72

Electrode type	
0	Standard version
Measuring element	
PB	Platinum ring
Shaft length	
2	120 mm / 4.72"
4	225 mm / 8.86"
5	360 mm / 14.17"
Plug-in head	
ESA	Plug-in head Pg 13.5, TOP 68, 16 bar / 232 psi, Ex
GSA	Plug-in head Pg 13.5, DIN coax, non-Ex
CPS72-	complete order code

Product structure CPS72D

Version	
7	Basic version
Measuring element	
PB	Platinum ring
Shaft length	
2	120 mm / 4.72"
4	225 mm / 8.86"
Approval	
I	Non-hazardous areas
G	ATEX II 1G EEx ia IIC T3/T4/T6
CPS72D-	complete order code

a) approval pending

广州晋合水处理设备有限公司



地 址：广东省广州市海珠区工业大道333号华新园区7幢218
电 话：020-88191905
传 真：020-61139917
邮 编：510300
邮 箱：jinhewater@jinhewater.com
网 址：<http://www.jinhewater.com>

Endress+Hauser 
People for Process Automation