



Level



Pressure



Flow



Temperature

Liquid
Analysis

Registration

Systems
Components

Services



Solutions

Technical Information

Cerabar T PMC131, PMP131, PMP135

Pressure Transducer

With ceramic and metal sensors

For absolute pressure and gauge pressure measurement up to 400 bar

Extremely stable, overload-resistant and reliable



Application

Cerabar T is a pressure transducer for measuring absolute pressure and gauge pressure in gases, vapors, liquids and dusts.

Hygienic and threaded connections are available as process connections.

Your benefits

This compact pressure transducer impresses with its well-engineered construction:

- High reproducibility and long-term stability.
- Finely graduated measuring ranges from vacuum up to 400 bar/6000 psi.
- Ceraphire® ceramic sensor: corrosion-proof, abrasion-proof and extremely overload-resistant.
- Deployed for pressure monitoring up to SIL 2 as per IEC 61508/IEC 61511-1
- Sensors
 - Dry capacitance ceramic sensor (Ceraphire®) for measuring ranges up to 40 bar: overload-resistant, vacuum-proof, stable against alternating load
 - Piezoresistive sensor with metal diaphragm for measuring ranges up to 400 bar

Function and system design

Device selection

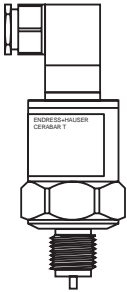
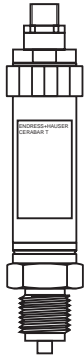
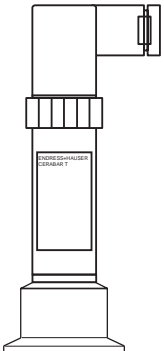
Cerabar T	PMC131	PMP131	PMP135
	 <p style="text-align: center;">P01-PMC131xx-14-xx-xx-xx-000</p> <p>With capacitive measuring cell and ceramic measuring diaphragm (Ceraphire®)</p>	 <p style="text-align: center;">P01-PMP131xx-14-xx-xx-xx-000</p> <p>With piezoresistive measuring cell and metallic measuring diaphragm</p>	 <p style="text-align: center;">P01-PMP135xx-14-xx-xx-xx-000</p> <p>With piezoresistive measuring cell and metallic measuring diaphragm for hygienic applications</p>
Field of application	Absolute pressure and gauge pressure	Absolute pressure and gauge pressure	Absolute pressure and gauge pressure in hygienic processes
Output	Current output 4 to 20 mA	<ul style="list-style-type: none"> - Current output 4 to 20 mA - Voltage output 0 to 10 V - Switch output PNP 	<ul style="list-style-type: none"> - 4 to 20 mA - Switch output PNP
Process connection	Thread: <ul style="list-style-type: none"> - G ½ - ½ MNPT and ¼ FNPT - G ½, bore 11 mm 	Thread: <ul style="list-style-type: none"> - G ½ - ½ MNPT and ¼ FNPT - ½ MNPT, bore 4 mm - G ¼ - ¼ MNPT, bore 3.5 mm - M 20 x 1.5 	Hygiene: <ul style="list-style-type: none"> - Clamp DN 22 (¾") - Tri-Clamp DN 25 to 38 (1" to 1½") - Tri-Clamp DN 40 to 51 (2") - G 1 - SMS 1½"
Measuring range	-1 to 0 bar/-100 to 0 kPa up to 0 to 40 bar/0 to 4 MPa	0 to 1 bar/0 to 100 kPa up to 0 to 400 bar/0 to 40 MPa	0 to 1 bar/0 to 100 kPa up to 0 to 40 bar/0 to 4 MPa
Process temperature	-20 to +100 °C	-25 °C to +70 °C	-25 to +100 °C (+135 °C for max. 1 hour)

Measuring principle

PMC131

The measuring pressure causes a slight deflection of the ceramic diaphragm of the sensor. The pressure-proportional change in capacitance is measured at the electrodes of the ceramic sensor. The ceramic sensor is a dry sensor, i.e. no fill fluid is required for the pressure transfer. This makes the sensor completely suitable for vacuums. Extremely high stability, comparable with the material Alloy, is achieved by using ultrapure Ceraphire® as the ceramic.

PMP131 and PMP135 with analog output

The process pressure acting upon the metallic separating diaphragm of the sensor is transmitted to a resistance bridge via a fluid. The pressure-proportional change of the bridge output voltage is measured and processed further.

PMP131 and PMP135 with switch output

The process pressure acting upon the metallic separating diaphragm of the sensor is transmitted to a resistance bridge via a fluid. A differential amplifier creates a standard signal from the pressure-proportional change in output voltage of the bridge. A comparator with an adjustable hysteresis compares this signal with the pre-set switch point and then activates the transistor output.

Measuring system

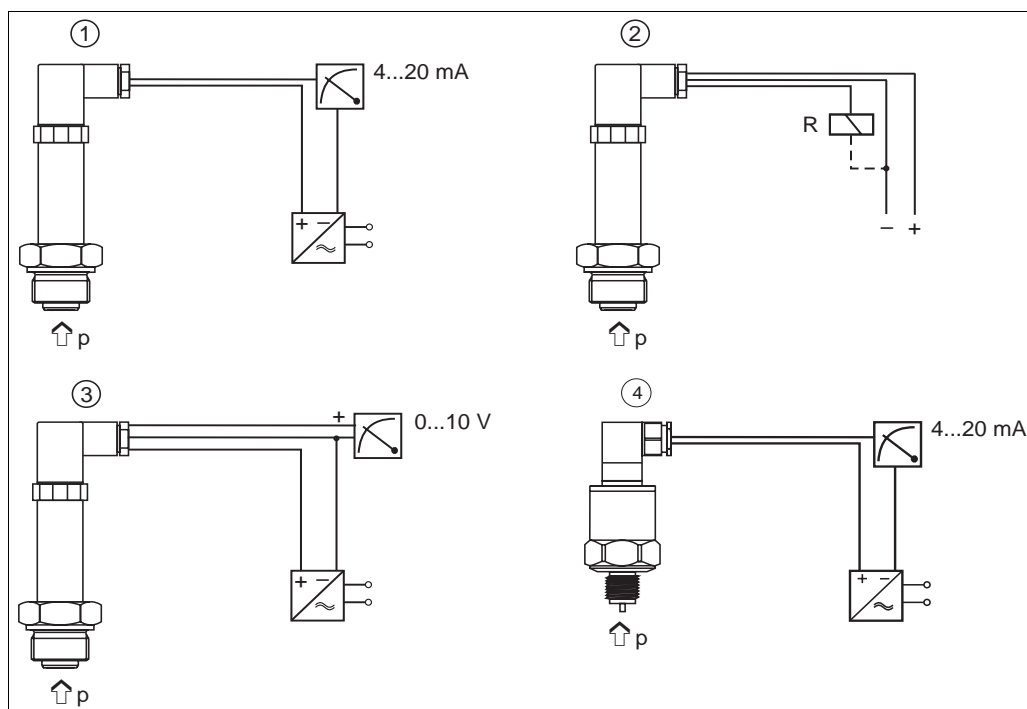

P01-PMx13xxx-14-xx-xx-xx-002

- 1 PMP131, PMP135: current output with transmitter power supply unit, e.g. RN 221N from Endress+Hauser
- 2 PMP131, PMP135: switch output with load, e.g. PLC, DCS, relay
- 3 PMC131: voltage output with transmitter power supply unit, e.g. RIA452 from Endress+Hauser
- 4 PMC131: current output with transmitter power supply unit, e.g. RN 221N from Endress+Hauser

Input

Measured variable	Absolute pressure or gauge pressure
Measuring range	up to 400 bar/6000 psi, see Page 18, "Ordering information" section

Output

Analog output (PMC131, PMP131, PMP135)

Output signal 4 to 20 mA

Load

PMC131
 $R_{Lmax} [\Omega] \leq (U_S - 1 \text{ V}) / 0.02 \text{ A}$

PMP131 and PMP135 (current output)
 $R_{Lmax} [\Omega] \leq (U_S - 12 \text{ V}) / 0.02 \text{ A}$ (R_{Lmax} : Maximum load resistance, U_S : Supply voltage)

PMP131 (voltage output)
 Load resistance $R_{Lmax} \geq 5 \text{ k}\Omega$, current consumption $\leq 6 \text{ mA}$

Switch output (PMP131, PMP135)

Output signal PNP switch output (positive voltage signal), rate depends on power supply voltage

Output current

- Switch status ON: $I_a \leq 500 \text{ mA}$
- Switch status OFF: $I_a \leq 1 \text{ mA}$

Power max. 6 W

Switch frequency max. 10 Hz

Input PLC

- Input resistance $R_i \leq 2 \text{ k}\Omega$
- Input current $I_i \geq 10 \text{ mA}$

Inductive loads To prevent electrical interference, only operate an inductive load (relays, contactors, solenoid valves) when directly connected to a protective circuit (free-wheeling diode or capacitor).

Power supply

PMC131

Plug/cable connection

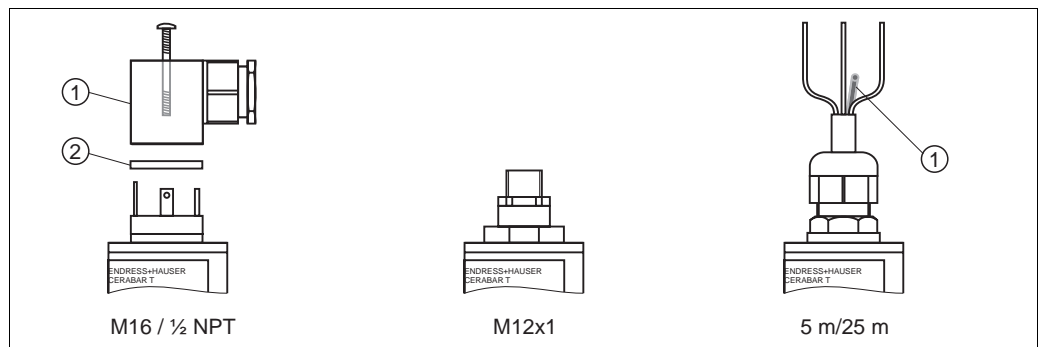

P01-PMC131xx-04-xx-xx-xx-001

Plug M 16 x 1.5 (DIN 43650/A), 1/2 NPT	Plug M 12x1	5 m/25 m cable
① Plug-in housing		① Reference pressure line
② Gasket		

Electrical connection: Analog/current output

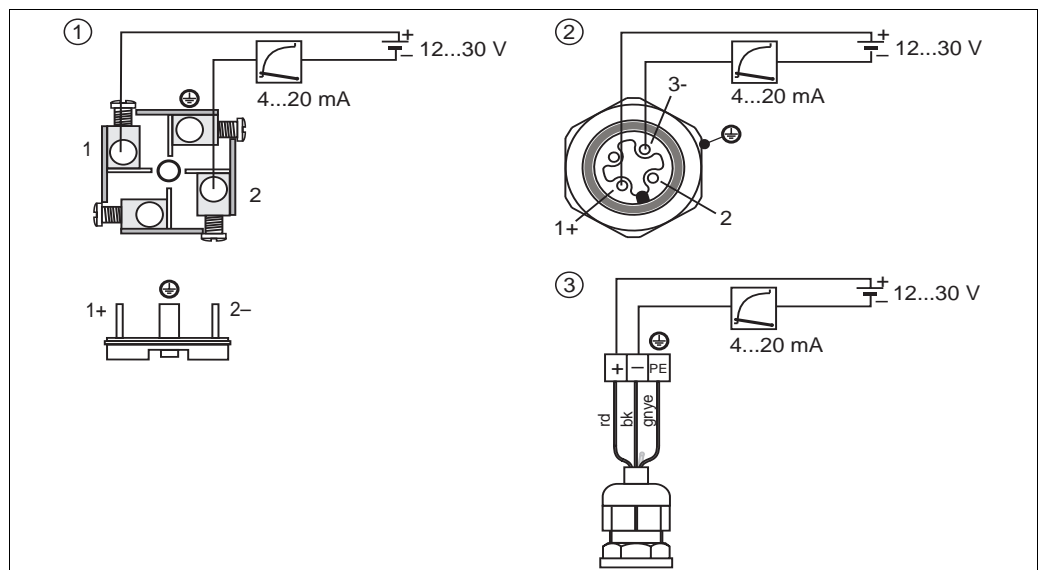

P01-PMC131xx-04-xx-xx-xx-002

- 1 Plug M 16 x 1.5 (DIN 43650/A), 1/2 NPT
- 2 Plug M 12 x 1
- 3 Cable (rd = red, bk = black, gnye = green-yellow)

PMP131 and PMP135

Plug/cable connection

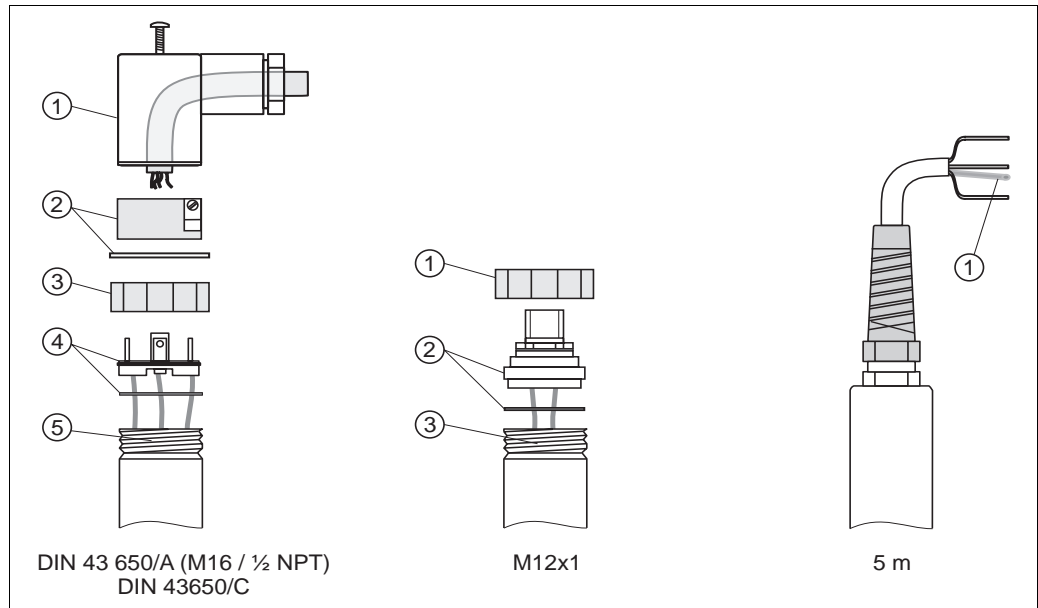

P01-PMP13xxx-04-xx-xx-xx-001

Plug M 16 x 1.5 (DIN 43650/A), 1/2 NPT Plug DIN 43650/C	Plug M 12x1	5 m cable, only analog output
① Plug-in housing	① Coupling nut	① Reference pressure line
② Plug-in jack with gasket	② Connector with gasket	
③ Coupling nut	③ Operating potentiometer (inner)	
④ Plug with O-ring		
⑤ Operating potentiometer (inner)		

Electrical connection: Analog/current output

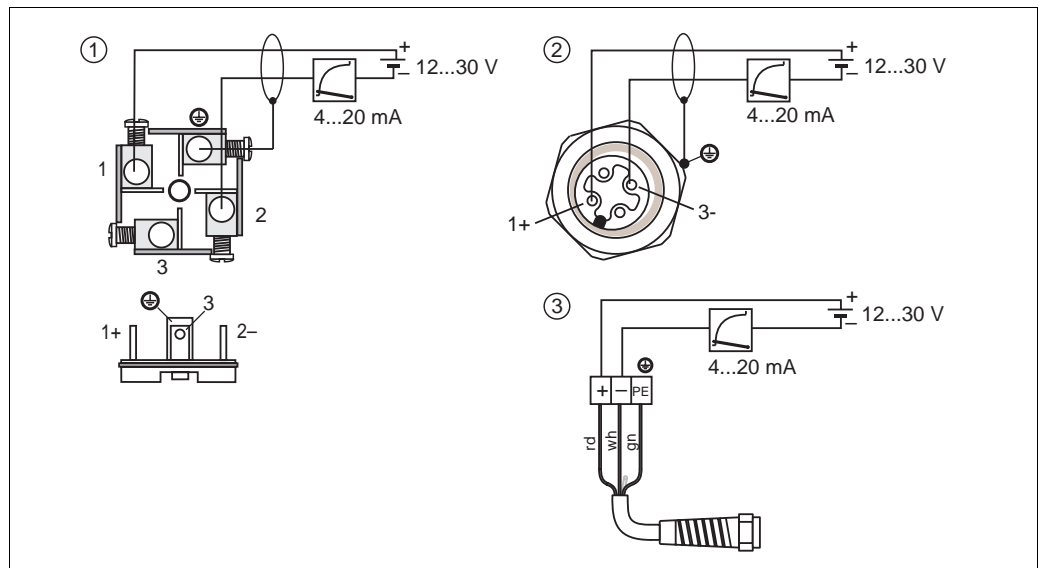

P01-PMP13xxx-04-xx-xx-xx-002

- 1 Plug M 16 x 1.5 (DIN 43650/A), 1/2 NPT and plug DIN 43650/C
- 2 Plug M 12 x 1
- 3 Cable (rd = red, wh = white, gn = green)

For electrical connection provided by customer use only shielded cable

Electrical connection (switch output)

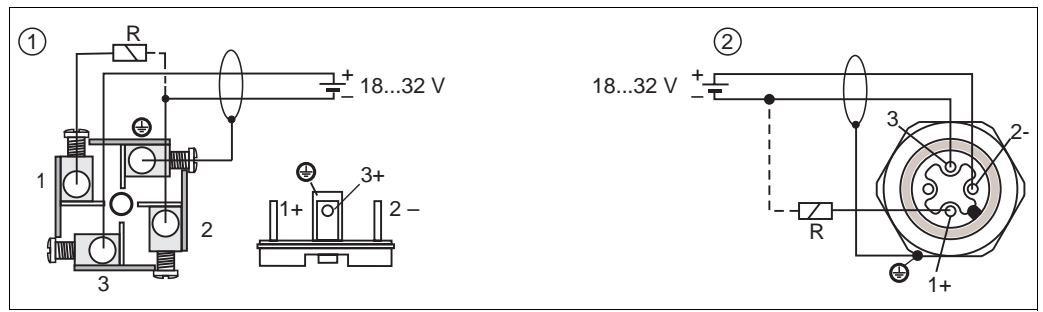

P01-PMP13xxx-04-xx-xx-xx-003

1 Plug M 16 x 1.5 (DIN 43650/A), 1/2 NPT

2 Plug M 12 x 1

R External load, e.g. relay, programmable logic controller, distributed control system

For electrical connection provided by customer use only shielded cable

PMP131

Electrical connection: Analog-/voltage output

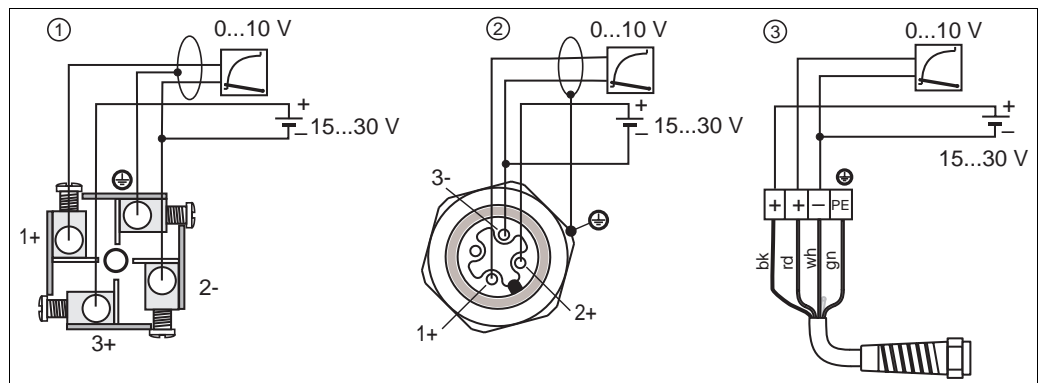

P01-PMP131xx-04-xx-xx-xx-001

1 Plug M 16 x 1,5 (DIN 43650/A), 1/2 NPT and plug DIN 43 650/C

2 Plug M 12 x 1

3 Cable (rd = red, wh = white, gn = green)

For electrical connection provided by customer use only shielded cable

Supply voltage

PMC131

11 to 30 V DC

PMP131 and PMP135 (current output, 2-wire version)

- For non-hazardous areas: 12 to 30 V DC
- Ex i: no-load voltage ≤ 26 V DC, short-circuit current ≤ 100 mA, power consumption ≤ 0.8 W

PMP131 (voltage output, 3-wire version)

- 15...30 V DC

PMP131 and PMP135 (switch output)

- 18 to 32 V DC, current consumption without load < 20 mA, with reverse polarity protection

Residual ripple

- Analog output: max. 5 % of supply voltage
- Switch output: max. 10 % of supply voltage

Cable entry

→ See Page 18, "Ordering information" section.

Performance characteristics

Reference operating conditions as per DIN IEC 60770, $T_U = 25\text{ °C}$

Long-term stability $\leq 0.15\%$ of URL per year

Maximum measured error of analog output (under reference operating conditions) The measured error comprises the non-linearity including hysteresis and non-reproducibility in accordance with the limit point method as per IEC 60770.

PMC131

- $\leq 0.5\%$ of $(URL - LRL) \times TD^1)$

Example: PMC131 version "AIR"

- Nominal value = 10 bar
- Upper range value (URV) = 6 bar
- Lower range value (LRV) = 0 bar

Turn down (is set at factory):

- $Nominal\ value / (URV - LRV) = 10\ bar / 6\ bar = 10:6$

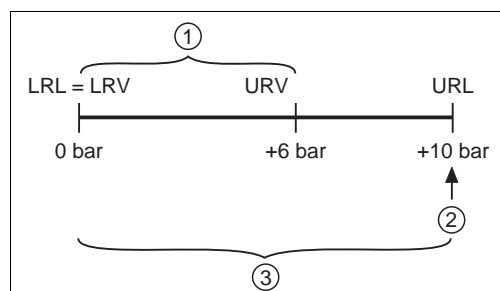

P01-PMx13xxx-05-xx-xx-xx-001

Example: PMC131 version "AIR"
set span: 0 to 6 bar; nominal value = 10 bar

- 1 Span set and calibrated at the factory (measuring range)
 - 2 Nominal value \cong Upper Range Limit (URL)
 - 3 Sensor measuring range
- LRL Lower Range Limit
URL Upper Range Limit
LRV Lower Range Value
URV Upper Range Value

PMP131 and PMP135

- $\leq 0.5\%$ of URL

Switch point **PMP131 and PMP135**

- Deviation: $\leq 1\%$ of URL
- Non-reproducibility: $\leq 0.5\%$ of URL

Rise time (T90) **PMC131**
20 ms

Settling time **PMP131 and PMP135**
2 to 5 ms

1) extended specifications apply to customer-specific measuring ranges

Thermal change of the lower range value and the span	<p>PMC131²⁾</p> <p>Zero output, -20 to +85 °C:</p> <ul style="list-style-type: none"> ■ typically 1.5 % of URL <p>Output span, -20 to +85 °C:</p> <ul style="list-style-type: none"> ■ Nominal value 0.4 to 40 bar: typically 0.8 % of URL ■ Nominal value 0.1bar: typically 1.0 % of URL
---	--

Temperature coefficient (T_K) for lower range value and span	<p>PMP131 and PMP135 (analog output)</p> <p>Zero output:</p> <ul style="list-style-type: none"> ■ typically: 0.2 % of URL/10 K ■ max.: 0.5 % of URL/10 K ■ Nominal value ≤ 6 bar: by 0.1 % of URL/10 K higher <p>Output signal:</p> <ul style="list-style-type: none"> ■ typically: 0.2 % of URL/10 K ■ max.: 0.5 % of URL/10 K <p>PMP131 and PMP135 (switch output)</p> <p>Switch point:</p> <ul style="list-style-type: none"> ■ typically: 0.2 % of URL/10 K ■ max.: 0.5 % of URL/10 K
---	--

Operating conditions (Installation instructions)

Orientation	anywhere
Installation instructions	<p>PMP131</p> <p>Process connection G 1/2 flush-mounted, max. torque 40 Nm</p>
Location dependence	<p>PMC131</p> <p>without influence</p> <p>PMP131 and PMP135</p> <p>Position-dependent zero point shift can be corrected by potentiometer setting, see also Page 16.</p>

2) for customer-specific measuring-ranges: values are doubled

Operating conditions (environment)

Ambient temperature range	PMC131 -20 to +85 °C
	PMP131 and PMP135 <ul style="list-style-type: none"> ■ For non-hazardous areas: -25 to +70 °C ■ Ex i: -25 to +65 °C
Storage temperature range	PMC131 -50 to +100 °C
	PMP131 and PMP135 -40 to +85 °C
Climate class	PMC131 4K4H as per DIN EN 60721-3
	PMP131 and PMP135 4Z with Z = 70 °C as per VDI/VDE 3540
Degree of protection	PMC131 <ul style="list-style-type: none"> ■ Plug M 16 x 1,5 (DIN 43650/A), ½ NPT: IP 65/NEMA 4X ■ Plug M12x1: IP 65/ NEMA 4 ■ Cable: IP 68/NEMA 6P (1 mWS/24 h)
	PMP131 and PMP135 <ul style="list-style-type: none"> ■ Plug M 16 x 1,5 (DIN 43650/A), ½ NPT: IP 65/NEMA 4X ■ Plug M 12x1 and gauge pressure sensors: IP 65/NEMA 4X ■ Plug M 12x1 and absolute pressure sensors: IP 68/NEMA 6P (1 mWS/24 h) ■ Cable: IP 68/NEMA 6P (1 mWS/24 h)
Vibration resistance	4M5 as per DIN EN 60721-3
Electromagnetic compatibility	PMC131 Interference emission as per EN 61326 electrical device class B, Interference immunity as per EN 61326 appendix A (industrial use).
	PMP131 and PMP135 Electromagnetic compatibility according to EN 61326; For details refer to the declaration of conformity (see ATEX Safety Instructions XA142P)

Operating conditions (process)

Process temperature range**PMC131**

- -20 to +100 °C
- Devices for oxygen application: -10 to +60 °C
(Version "S" for feature 30 "Sensor gasket")

PMP131

-25 to +70 °C

PMP135

-25 to +100 °C (+135 °C for max. 1 hour)

Extreme jumps in temperature can result in temporary measuring errors. Temperature compensation takes effect after several minutes. Internal temperature compensation is faster the smaller the temperature jump and the longer the time interval.

Overload resistance

→ See Page 18, "Ordering information" section.

Vacuum resistance**PMC131**

- with URV > 200 mbar / > 80 inH₂O / > 1.5 psi: 0 mbar_{abs}
- with URV = 200 mbar / = 50 inH₂O or 80 inH₂O: 500 mbar_{abs}
(Versions "D12", "D38", "W6O", "S4N")
- with URV = 20 mbar or 100 mbar / = 1.5 psi / = 15 inH₂O or 30 inH₂O: 700 mbar_{abs}
(Versions "D10", "D3W", "D31", "Q4D", "V6F", "W6N", "W6R")



PMP131 and PMP135

10 mbar_{abs}

Pressure specifications

- The MWP (maximum working pressure) of the device is specified on the nameplate. It depends on the weakest element, with regard to pressure, of the selected components. See the following sections:
 - → Page 18 ff, "Ordering information" section, feature 50 "Measuring range; MWP; Nominal value; OPL" or "Sensor range; MWP; OPL".
 - → Page 12 ff, "Mechanical construction" section.
 The MWP specification on the nameplate is based on a reference temperature of +20 °C and can be present over an unlimited period of time.
- The test pressure corresponds to the overload limit of the measuring device (Over Pressure Limit OPL) and must only be present for a limited period of time.

Certificates and approvals

CE mark	The device meets the legal requirements of the EC directives. Endress+Hauser confirms that the device has been successfully tested by applying the CE mark.
Ex approvals	All explosion protection data are given in separate documentation which is available upon request. The Ex documentation is supplied as standard with all devices approved for use in explosion hazardous areas. → See also Page 22, "Safety Instructions" section.
Pressure Equipment Directive (PED)	This measuring device corresponds to Article 3 (3) of the EC directive 97/23/EC (Pressure Equipment Directive) and has been designed and manufactured according to good engineering practice.
Functional safety SIL 2	The Cerabar T PMP131 and PMP135 pressure transducers with 4 to 20 mA electronics have been assessed by an independent body according to the standards IEC 61508/IEC 61511-1. These devices can be used for monitoring process pressure up to SIL 2. → For a detailed description of safety functions with Cerabar T, settings and characteristic quantities for functional safety, see the "Functional Safety Manual – Cerabar T SD160P".
Suitability for hygienic processes	<p>The Cerabar T PMP135 is suitable for the employment in hygienic processes. An overview of permitted process connections on page 14. Many versions meet the requirements of 3A-Sanitary Standard No. 74 and are certified by the EHEDG.</p> <p> Note! The gap-free connections can be cleaned without residue using the usual cleaning methods.</p> <div style="text-align: right;">   </div>
TSE Certificate of Suitability	<p>Cerabar T PMP135 The following applies to wetted device components: They do not contain any materials derived from animals. No auxiliaries or operating materials derived from animals are used in production or processing. Process wetted device components are listed in the "Mechanical construction" and "Ordering information" sections.</p>
Standards and guidelines	<p>DIN EN 60770 (IEC 60770): Transmitters for controlling in systems used in industrial process technology Part 1: Methods for evaluating the operating behavior.</p> <p>DIN EN 61003-1, Edition:1993-12 Systems used in industrial process technology; Devices with analog inputs and two-point or multi-point behavior; Part 1: Methods for evaluating the operating behavior.</p> <p>DIN 16086: Electrical pressure measuring devices, pressure sensors, transmitters, pressure measuring devices Terms, specifications in data sheets.</p> <p>IEC 60592 Degrees of protection provided by enclosures (IP-Code).</p> <p>EN 61326: Electrical equipment for control technology and laboratory application – EMC requirements.</p> <p>IEC 61010 Safety requirements for electrical equipment for measurement, control and laboratory use.</p> <p>NAMUR Association for Standards for Control and Regulation in the Chemical Industry.</p>
Registered trademarks	<p>Ceraphire® Registered trademark of Endress+Hauser GmbH+Co. KG, Maulburg, Germany (→ see also www.endress.com/ceraphire)</p>

Ordering information

PMC131

10		Electrical connection:			
A1	Plug ISO 4400, M 16, IP 65/NEMA 4X				
A2	Plug ISO 4400, ½ NPT, IP 65/NEMA 4X				
A3	5 m cable, IP 68/NEMA 6P				
A4	25 m cable, IP 68/NEMA 6P				
A5	Plug M 12, IP 65/NEMA 4				
B1	Plug ISO 4400, M 16, IP 65, ATEX II 3 G EEx nA II T4				
B3	5 m cable, IP 68, ATEX II 3 G EEx nA II T4				
B5	Plug M 12, IP 65, ATEX II 3 G EEx nA II T4				
C1	Plug ISO 4400, M 16, NEMA 4X, CSA GP				
C2	Plug ISO 4400, ½ NPT, NEMA 4X, CSA GP				
C3	5m cable, IP 68/NEMA 6P, CSA GP				
C5	Plug M12, IP 65/NEMA 4, CSA GP				
20		Process connection:			
1	Thread ISO 228 G ½, AISI 304				
2	Thread ANSI ½ MNPT ¼ FNPT, AISI 304				
5	Thread ISO 228 G ½ bore 11 mm, AISI 304				
30		Sensor seal:			
F	FKM Viton				
S	FKM Viton, oxygen application				
40		Additional options:			
1	Without additional equipment				
S	GL (German Lloyd) marine certificate				
2	Final inspection report				
50		Measuring range; MWP; Nominal value; OPL:			
		Measuring range	MWP (Maximum Working Pressure)	Nominal value	OPL (Over Pressure Limit)
		Sensors for gauge pressure			
	A1G	0 to 1 bar / 0 to 100 kPa	6.7 bar	1 bar	10 bar / 1 MPa
	A1H ¹⁾	0 to 1.6 bar / 0 to 160 kPa	12 bar	2 bar	18 bar / 1.8 MPa
	A1K	0 to 2 bar / 0 to 200 kPa	12 bar	2 bar	18 bar / 1.8 MPa
	A1Q	0 to 4 bar / 0 to 400 kPa	16.7 bar	4 bar	25 bar / 2.5 MPa
	A1R ¹⁾	0 to 6 bar / 0 to 600 kPa	26.7 bar	10 bar	40 bar / 4 MPa
	A1S	0 to 10 bar / 0 to 1 MPa	26.7 bar	10 bar	40 bar / 4 MPa
	A1T ¹⁾	0 to 16 bar / 0 to 1.6 MPa	26.7 bar	20 bar	40 bar / 4 MPa
	A1V	0 to 20 bar / 0 to 2 MPa	26.7 bar	20 bar	40 bar / 4 MPa
	A1W ¹⁾	0 to 25 bar / 0 to 2.5 MPa	40 bar	40 bar	60 bar / 6 MPa
	A1X	0 to 40 bar / 0 to 4 MPa	40 bar	40 bar	60 bar / 6 MPa
	A3C ¹⁾	-1 to 0 bar / -100 to 0 kPa	6.7 bar	2 bar	10 bar / 1 MPa
	A3E ¹⁾	-1 to 1 bar / -100 to 100 kPa	6.7 bar	2 bar	10 bar / 1 MPa
	A3G ¹⁾	-1 to 3 bar / -100 to 300 kPa	16.7 bar	4 bar	25 bar / 2.5 MPa
	A3K ¹⁾	-1 to 9 bar / -100 to 900 kPa	26.7 bar	10 bar	40 bar / 4 MPa
	A3N ¹⁾	-1 to 15 bar / -0.1 to 1.5 MPa	26.7 bar	20 bar	40 bar / 4 MPa
	D10	0 to 100 mbar / 0 to 10 kPa	2.7 bar	0.1 bar	4 bar / 400 kPa
	D12 ¹⁾	0 to 200 mbar / 0 to 20 kPa	3.3 bar	0.2 bar	5 bar / 500 kPa
	D14	0 to 400 mbar / 0 to 40 kPa	5.3 bar	0.4 bar	8 bar / 800 kPa
	D3W	-20 to 20 mbar / -2 to 2 kPa	2.7 bar	0.2 bar	4 bar / 400 kPa
	D31 ¹⁾	-100 to 100 mbar / -10 to 10 kPa	3.3 bar	0.2 bar	5 bar / 500 kPa
	D38 ¹⁾	-200 to 200 mbar / -20 to 20 kPa	3.3 bar	0.4 bar	5 bar / 500 kPa
	D39 ¹⁾	-300 to 300 mbar / -30 to 30 kPa	5.3 bar	1 bar	8 bar / 800 kPa
PMC131					Order code

→ For continuation of ordering information of PMC131, see the following page.

1) Span set and calibrated at the factory

PMC131 (continued)

50				Measuring range; MWP; Nominal value; OPL:			
				Measuring range	MWP (Maximum Working Pressure)	Nominal value	OPL (Over Pressure Limit)
				Sensors for gauge pressure			
				Q4D 0 to 1.5 psi	40 psi	1.5 psi	60 psi
				Q4F ¹⁾ 0 to 5 psi	80 psi	6 psi	120 psi
				Q4H 0 to 15 psi	100 psi	15 psi	150 psi
				Q4K 0 to 30 psi	180 psi	30 psi	270 psi
				Q4N ¹⁾ 0 to 50 psi	250 psi	60 psi	375 psi
				Q4R 0 to 150 psi	400 psi	150 psi	600 psi
				Q4S 0 to 300 psi	400 psi	300 psi	600 psi
				Q4T ¹⁾ 0 to 500 psi	600 psi	600 psi	900 psi
				V6F ¹⁾ -1.5 to 1.5 psi	50 psi	3 psi	75 psi
				V6N ¹⁾ -15 to 15 psi	100 psi	30 psi	150 psi
				V6R ¹⁾ -15 to 30 psi	250 psi	60 psi	375 psi
				V6S -15 to 60 psi	250 psi	60 psi	375 psi
				V6V -15 to 150 psi	400 psi	150 psi	600 psi
				S4N ¹⁾ 0 to 50 inH ₂ O	50 psi	3 psi	75 psi
				S4Q ¹⁾ 0 to 100 inH ₂ O	80 psi	6 psi	120 psi
				W6N ¹⁾ -15 to 15 inH ₂ O	40 psi	3 psi	60 psi
				W6O ¹⁾ -80 to 80 inH ₂ O	50 psi	6 psi	75 psi
				W6R ¹⁾ -15 to 30 inH ₂ O	50 psi	3 psi	75 psi
				Sensors for absolute pressure			
				A2G 0 to 1 bar / 0 to 100 kPa	6.7 bar	1 bar	10 bar / 1 MPa
				A2H ¹⁾ 0 to 1.6 bar / 0 to 160 kPa	12 bar	2 bar	18 bar / 1.8 MPa
				A2K 0 to 2 bar / 0 to 200 kPa	12 bar	2 bar	18 bar / 1.8 MPa
				A2Q 0 to 4 bar / 0 to 400 kPa	16.7 bar	4 bar	25 bar / 2.5 MPa
				A2R ¹⁾ 0 to 6 bar / 0 to 600 kPa	26.7 bar	10 bar	40 bar / 4 MPa
				A2S 0 to 10 bar / 0 to 1 MPa	26.7 bar	10 bar	40 bar / 4 MPa
				A2T ¹⁾ 0 to 16 bar / 0 to 1.6 MPa	26.7 bar	20 bar	40 bar / 4 MPa
				A2V 0 to 20 bar / 0 to 2 MPa	26.7 bar	20 bar	40 bar / 4 MPa
				A2W ¹⁾ 0 to 25 bar / 0 to 2.5 MPa	40 bar	40 bar	60 bar / 6 MPa
				A2X 0 to 40 bar / 0 to 4 MPa	40 bar	40 bar	60 bar / 6 MPa
				D20 ¹⁾ 0 to 100 mbar / 0 to 10 kPa	3.3 bar	0.2 bar	5 bar / 500 kPa
				D22 0 to 200 mbar / 0 to 20 kPa	3.3 bar	0.2 bar	5 bar / 500 kPa
				D24 0 to 400 mbar / 0 to 40 kPa	5.3 bar	0.4 bar	8 bar / 800 kPa
				R4D ¹⁾ 0 to 1.5 psi	50 psi	3 psi	75 psi
				R4F ¹⁾ 0 to 5 psi	80 psi	6 psi	120 psi
				R4H 0 to 15 psi	100 psi	15 psi	150 psi
				R4K 0 to 30 psi	180 psi	30 psi	270 psi
				R4N ¹⁾ 0 to 50 psi	250 psi	60 psi	375 psi
				R4R 0 to 150 psi	400 psi	150 psi	600 psi
				R4S 0 to 300 psi	400 psi	300 psi	600 psi
				R4T ¹⁾ 0 to 500 psi	600 psi	600 psi	900 psi
PMC131				Complete order code			

1) Span set and calibrated at the factory

PMP131		10		Electrical connection:		
	A1			Plug ISO 4400, M 16, IP 65/NEMA 4X (DIN 43650/A)		
	A2			Plug ISO 4400, ½ NPT, IP 65/NEMA 4X		
	A3			5 m cable, IP 68/NEMA 6P		
	A4			Plug M 12, IP 65/NEMA 4X		
	A5			Plug DIN 43650/C, IP65, NEMA 4X		
20				Process connection:		
	B			Thread ISO 228 G ½, Seal DIN 3852, AISI 304, flush-mounted		
	1			Thread ISO 228 G ½, AISI 304		
	2			Thread ANSI ½ MNPT ¼ FNPT, AISI 304		
	3			Thread ANSI ½ MNPT bore 4 mm, AISI 304		
	4			Thread ISO 228 G ¼, AISI 304		
	5			Thread ANSI ¼ MNPT bore 3.5 mm, AISI 304		
	6			Thread M 20 x 1.5		
30				Output:		
	0			Analog current output 4 to 20 mA, SIL		
	D			Analog current output 4 to 20 mA, SIL, ATEX II 1/2 G EEx ib IIC T6		
	1			Analog current output 4 to 20 mA, SIL, ATEX II 2 G EEx ib IIC T6		
	5			Analog current output 4 to 20 mA, SIL, ATEX II 3 G EEx nA II T6		
	2			Switch output PNP, 3-wire		
	3			Switch output PNP, 3-wire, ATEX II 3 G EEx nA II T6		
	6			Analog voltage output 0...10 V		
40				Additional options:		
	1			Without additional equipment		
	S			GL/RINA marine approval		
	2			Final inspection report		
50				Sensor range; MWP; OPL:		
				Sensor range	MWP (maximum working pressure)	OPL (over pressure limit)
				Sensors for gauge pressure		
	A1G			0 to 1 bar / 0 to 100 kPa	2.7 bar	4 bar / 400 kPa
	A1H			0 to 1.6 bar / 0 to 160 kPa	4 bar	6.4 bar / 640 kPa
	A1N			0 to 2.5 bar / 0 to 250 kPa	6.7 bar	10 bar / 1 MPa
	A1Q			0 to 4 bar / 0 to 400 kPa	10.7 bar	16 bar / 1.6 MPa
	A1R			0 to 6 bar / 0 to 600 kPa	16 bar	24 bar / 2.4 MPa
	A1S			0 to 10 bar / 0 to 1 MPa	25 bar	40 bar / 4 MPa
	A1T			0 to 16 bar / 0 to 1.6 MPa	25 bar	64 bar / 6.4 MPa
	A1W			0 to 25 bar / 0 to 2.5 MPa	25 bar	100 bar / 10 MPa
	A1X			0 to 40 bar / 0 to 4 MPa	60 bar	160 bar / 16 MPa
	A1Z			0 to 60 bar / 0 to 6 MPa	60 bar	240 bar / 24 MPa
	A70			0 to 100 bar / 0 to 10 MPa	100 bar	400 bar / 40 MPa
	A71			0 to 160 bar / 0 to 16 MPa	160 bar	600 bar / 60 MPa
	A73			0 to 250 bar / 0 to 25 MPa	250 bar	600 bar / 60 MPa
	A74			0 to 400 bar / 0 to 40 MPa	400 bar	600 bar / 60 MPa
	Q4H			0 to 15 psi	40 psi	60 psi
	Q4K			0 to 30 psi	100 psi	150 psi
	Q4N			0 to 50 psi	160 psi	240 psi
	Q4R			0 to 150 psi	400 psi	600 psi
	Q4S			0 to 300 psi	400 psi	1500 psi
	Q4T			0 to 500 psi	1000 psi	2400 psi
	Q4V			0 to 1000 psi	1000 psi	3600 psi
	Q70			0 to 1500 psi	1500 psi	6000 psi
	Q73			0 to 3000 psi	3000 psi	9000 psi
	Q74			0 to 6000 psi	6000 psi	9000 psi
PMP131				Order code		

→ For continuation of ordering information of PMP131, see the following page.

PMP131 (continued)

50					Sensor range; MWP; OPL:		
					Sensor range	MWP (maximum working pressure)	OPL (over pressure limit)
					Sensors for absolute pressure		
				A2G	0 to 1 bar / 0 to 100 kPa	2.7 bar	4 bar / 400 kPa
				A2H	0 to 1.6 bar / 0 to 160 kPa	4 bar	6.4 bar / 640 kPa
				A2N	0 to 2.5 bar / 0 to 250 kPa	6.7 bar	10 bar / 1 MPa
				A2Q	0 to 4 bar / 0 to 400 kPa	10.7 bar	16 bar / 1.6 MPa
				A2R	0 to 6 bar / 0 to 600 kPa	16 bar	24 bar / 2.4 MPa
				A2S	0 to 10 bar / 0 to 1 MPa	25 bar	40 bar / 4 MPa
				A2T	0 to 16 bar / 0 to 1.6 MPa	25 bar	64 bar / 6.4 MPa
				A2W	0 to 25 bar / 0 to 2.5 MPa	25 bar	100 bar / 10 MPa
				A2X	0 to 40 bar / 0 to 4 MPa	60 bar	160 bar / 16 MPa
				A2Z	0 to 60 bar / 0 to 6 MPa	60 bar	240 bar / 24 MPa
				B70	0 to 100 bar / 0 to 10 MPa	100 bar	400 bar / 40 MPa
				B71	0 to 160 bar / 0 to 16 MPa	160 bar	600 bar / 60 MPa
				B73	0 to 250 bar / 0 to 25 MPa	250 bar	600 bar / 60 MPa
				B74	0 to 400 bar / 0 to 40 MPa	400 bar	600 bar / 60 MPa
				R4H	0 to 15 psi	40 psi	60 psi
				R4K	0 to 30 psi	100 psi	150 psi
				R4N	0 to 50 psi	160 psi	240 psi
				R4R	0 to 150 psi	400 psi	600 psi
				R4S	0 to 300 psi	400 psi	1500 psi
				R4T	0 to 500 psi	1000 psi	2400 psi
				R4V	0 to 1000 psi	1000 psi	3600 psi
				R70	0 to 1500 psi	1500 psi	6000 psi
				R73	0 to 3000 psi	3000 psi	9000 psi
				R74	0 to 6000 psi	6000 psi	9000 psi
PMP131					Complete order code		

PMP135

10	Electrical connection:			
	A1	Plug ISO 4400, M 16, IP 65/NEMA 4X		
	A2	Plug ISO 4400, ½ NPT, IP 65/NEMA 4X		
	A3	5 m cable, IP 68/NEMA 6P		
	A4	Plug M 12, IP 65/NEMA 4X		
20	Process connection:			
	F	Clamp ISO 2852, DN 22 (¾"), AISI 316L, 3A, DIN 32676 DN 20, EHEDG		
	G	Tri-Clamp ISO 2852, DN 25 to 38 (1" to 1½"), AISI 316L, 3A, DIN 32676 DN 25 to 40, EHEDG		
	H	Tri-Clamp ISO 2852, DN 40 to 51 (2"), AISI 316L, 3A, DIN 32676 DN 50, EHEDG		
	M	Thread ISO 228, G 1, with metallic sealing taper, AISI 316L, flush-mounted, adapter 52005087		
	N	Thread ISO 228, G 1, with sealing surface for flush-mounted installation, AISI 316L, adapter 52001051		
30	Output:			
	0	Analog 4 to 20 mA, SIL		
	D	Analog 4 to 20 mA, SIL, ATEX II 1/2 G EEx ib IIC T6		
	1	Analog 4 to 20 mA, SIL, ATEX II 2 G EEx ib IIC T6		
	5	Analog 4 to 20 mA, SIL, ATEX II 3 G EEx nA II T6		
40	Additional options:			
	1	Without additional equipment		
	C	EN10204-3.1 material (wetted) inspection certificate		
	2	Final inspection report		
50	Sensor range; MWP; OPL:			
		Sensor range	MWP (maximum working pressure)	OPL (over pressure limit)
		Sensors for gauge pressure		
	A1G	0 to 1 bar / 0 to 100 kPa	2.7 bar	4 bar / 400 kPa
	A1H	0 to 1.6 bar / 0 to 160 kPa	4 bar	6.4 bar / 640 kPa
	A1N	0 to 2.5 bar / 0 to 250 kPa	6.7 bar	10 bar / 1 MPa
	A1Q	0 to 4 bar / 0 to 400 kPa	10.7 bar	16 bar / 1.6 MPa
	A1R	0 to 6 bar / 0 to 600 kPa	16 bar	24 bar / 2.4 MPa
	A1S	0 to 10 bar / 0 to 1 MPa	25 bar	40 bar / 4 MPa
	A1T	0 to 16 bar / 0 to 1.6 MPa	25 bar	64 bar / 6.4 MPa
	A1W	0 to 25 bar / 0 to 2.5 MPa	25 bar	100 bar / 10 MPa
	A1X	0 to 40 bar / 0 to 4 MPa	60 bar	160 bar / 16 MPa
	Q4H	0 to 15 psi	40 psi	60 psi
	Q4K	0 to 30 psi	100 psi	150 psi
	Q4N	0 to 50 psi	160 psi	240 psi
	Q4R	0 to 150 psi	400 psi	600 psi
	Q4S	0 to 300 psi	400 psi	1500 psi
	Q4T	0 to 500 psi	1000 psi	2400 psi
		Sensors for absolute pressure		
	A2G	0 to 1 bar / 0 to 100 kPa	2.7 bar	4 bar / 400 kPa
	A2H	0 to 1.6 bar / 0 to 160 kPa	4 bar	6.4 bar / 640 kPa
	A2N	0 to 2.5 bar / 0 to 250 kPa	6.7 bar	10 bar / 1 MPa
	A2Q	0 to 4 bar / 0 to 400 kPa	10.7 bar	16 bar / 1.6 MPa
	A2R	0 to 6 bar / 0 to 600 kPa	16 bar	24 bar / 2.4 MPa
	A2S	0 to 10 bar / 0 to 1 MPa	25 bar	40 bar / 4 MPa
	A2T	0 to 16 bar / 0 to 1.6 MPa	25 bar	64 bar / 6.4 MPa
	A2W	0 to 25 bar / 0 to 2.5 MPa	25 bar	100 bar / 10 MPa
	A2X	0 to 40 bar / 0 to 4 MPa	60 bar	160 bar / 16 MPa
	R4H	0 to 15 psi	40 psi	60 psi
	R4K	0 to 30 psi	100 psi	150 psi
	R4N	0 to 50 psi	160 psi	240 psi
	R4R	0 to 150 psi	400 psi	600 psi
	R4S	0 to 300 psi	400 psi	1500 psi
R4T	0 to 500 psi	1000 psi	2400 psi	
PMP135				Complete order code

广州晋合水处理设备有限公司



地 址：广东省广州市海珠区工业大道333号华新园区7幢218

电 话：020-88191905

传 真：020-61139917

邮 编：510300

邮 箱：jinhewater@jinhewater.com

网 址：<http://www.jinhewater.com>

Endress+Hauser 
People for Process Automation